

Dell™ PowerEdge™ 2950 Systems

Hardware Owner's Manual

Notes, Notices, and Cautions



NOTE: A NOTE indicates important information that helps you make better use of your computer.



NOTICE: A NOTICE indicates either potential damage to hardware or loss of data and tells you how to avoid the problem.



CAUTION: A CAUTION indicates a potential for property damage, personal injury, or death.

Information in this document is subject to change without notice.

© 2006 Dell Inc. All rights reserved.

Reproduction in any manner whatsoever without the written permission of Dell Inc. is strictly forbidden.

Trademarks used in this text: *Dell*, the *DELL* logo, *Inspiron*, *Dell Precision*, *Dimension*, *OptiPlex*, *Latitude*, *PowerEdge*, *PowerVault*, *PowerApp*, *PowerConnect*, *XPS*, and *Dell OpenManage* are trademarks of Dell Inc.; *Intel*, *Pentium*, and *Celeron* are registered trademarks, and *Xeon* is a trademark of Intel Corporation; *Microsoft* and *Windows* are registered trademarks of Microsoft Corporation; *EMC* is a registered trademark of EMC Corporation.

Other trademarks and trade names may be used in this document to refer to either the entities claiming the marks and names or their products. Dell Inc. disclaims any proprietary interest in trademarks and trade names other than its own.

Model EMS01

January 2006

Contents

1	About Your System.	11
	Other Information You May Need	11
	Accessing System Features During Startup	12
	Front-Panel Features and Indicators	13
	Hard-Drive Indicator Codes.	15
	Back-Panel Features and Indicators	17
	Connecting External Devices	17
	Power Indicator Codes	18
	NIC Indicator Codes	19
	LCD Status Messages	19
	Solving Problems Described by LCD Status Messages	27
	Removing LCD Status Messages	27
	System Messages	28
	Warning Messages	35
	Diagnostics Messages	35
	Alert Messages	35
2	Using the System Setup Program	37
	Entering the System Setup Program	37
	Responding to Error Messages.	37
	Using the System Setup Program.	38
	System Setup Options	38
	Main Screen	38
	CPU Information Screen	41
	Integrated Devices Screen.	42
	Serial Communication Screen	43
	System Security Screen	43
	Exit Screen	44

System and Setup Password Features.	45
Using the System Password	45
Using the Setup Password	47
Disabling a Forgotten Password.	48
Baseboard Management Controller Configuration	48
Entering the BMC Setup Module	49
BMC Setup Module Options	49
3 Installing System Components	51
Recommended Tools	51
Inside the System	52
Front Bezel	53
Removing the Front Bezel.	53
Replacing the Front Bezel.	54
Opening and Closing the System	54
Opening the System.	54
Closing the System	55
Hard Drives.	55
Before You Begin	56
Removing a Drive Blank	56
Installing a Drive Blank	57
Removing a Hot-Plug Hard Drive	57
Installing a Hot-Plug Hard Drive	57
Replacing a Hard-Drive Carrier	58
Removing a Hard Drive From a Hard-Drive Carrier.	58
Installing a SAS Hard Drive Into a SATAu Drive Carrier	59
Installing a SATA Hard Drive Into a SATA Drive Carrier	60
Installing a SATA Hard Drive and Interposer Card Into a SATAu Hard-Drive Carrier	61
Power Supplies	62
Removing a Power Supply	63
Replacing a Power Supply	64
Removing the Power Supply Blank.	64
Installing the Power Supply Blank	65

System Fans	65
Removing a System Fan.	65
Replacing a Cooling Fan	66
Cooling Shroud	66
Removing the Cooling Shroud	67
Installing the Cooling Shroud	67
Fan Brackets	68
Removing the Fan Bracket	68
Replacing the Fan Bracket	69
SAS Controller Daughter Card	69
Installing a SAS Controller Daughter Card	70
SAS and SAS RAID Controller Daughter Card Cabling Guidelines.	72
Removing a SAS Controller Daughter Card.	74
RAID Battery	74
Installing a RAID Battery	74
Removing a RAID Battery.	75
Configuring the Boot Device	76
Expansion Cards	76
Expansion Card Installation Guidelines.	76
Installing an Expansion Card	76
Removing an Expansion Card.	78
Expansion-Card Cage	78
Removing the Expansion-Card Cage	78
Replacing the Expansion-Card Cage	79
Installing a RAC Card	80
Optical Drive	81
Removing the Optical Drive.	81
Installing the Optical Drive	82
Diskette Drive	83
Removing the Diskette Drive From the System.	83
Installing the Diskette Drive Into the System.	84
Removing the Diskette Drive From the Drive Carrier.	85
Installing the Diskette Drive Into the Drive Carrier.	85

SCSI Tape Drive	86
Removing and Installing an Internal SCSI Tape Drive	86
Removing and Replacing the Tape Drive Cable Retention Bracket	88
System Memory	89
General Memory Module Installation Guidelines	89
Non-Optimal Memory Configurations	90
Memory Sparing Support.	90
Memory Mirroring Support.	90
Installing Memory Modules.	90
Removing Memory Modules	92
Activating the Integrated NIC TOE.	93
Processors	93
Removing a Processor	93
Installing a Processor.	95
System Battery	96
Replacing the System Battery	96
Expansion-Card Riser Boards	98
Removing the Left Expansion-Card Riser Board	98
Installing the Left Riser Board	99
Removing the Central Riser Board	100
Installing the Central Riser Board	100
Sideplane Board	101
Removing the Sideplane Board.	101
Installing the Sideplane Board	102
SAS Backplane Board	103
Removing the SAS Backplane Board.	103
Installing the SAS Backplane Board	104
Control Panel Assembly (Service-only Procedure)	105
Removing the Control Panel Assembly.	105
Installing the Control Panel Assembly	106
System Board (Service-only Procedure)	107
Removing the System Board	107
Installing the System Board.	108

4	Troubleshooting Your System	111
	Safety First—For You and Your System	111
	Start-Up Routine	111
	Checking the Equipment.	112
	Troubleshooting IRQ Assignment Conflicts.	112
	Troubleshooting External Connections	112
	Troubleshooting the Video Subsystem	113
	Troubleshooting the Keyboard	113
	Troubleshooting the Mouse.	114
	Troubleshooting Basic I/O Functions	114
	Troubleshooting a Serial I/O Device	115
	Troubleshooting a USB Device	115
	Troubleshooting a NIC	116
	Troubleshooting a Wet System.	116
	Troubleshooting a Damaged System.	117
	Troubleshooting the System Battery.	118
	Troubleshooting Power Supplies	118
	Troubleshooting System Cooling Problems	119
	Troubleshooting a Fan	119
	Troubleshooting System Memory	120
	Troubleshooting a Diskette Drive	121
	Troubleshooting an Optical Drive	123
	Troubleshooting an External SCSI Tape Drive.	123
	Troubleshooting a Hard Drive	124
	Troubleshooting a SAS or SAS RAID Controller Daughter Card	126
	Troubleshooting Expansion Cards.	127
	Troubleshooting the Microprocessors	128

5	Running the System Diagnostics	131
	Using Server Administrator Diagnostics	131
	System Diagnostics Features	131
	When to Use the System Diagnostics	131
	Running the System Diagnostics	132
	System Diagnostics Testing Options	132
	Using the Custom Test Options	132
	Selecting Devices for Testing	132
	Selecting Diagnostics Options	133
	Viewing Information and Results	133
6	Jumpers and Connectors	135
	System Board Jumpers	135
	System Board Connectors	137
	SAS Backplane Board Connectors	139
	Sideplane Board Connectors	142
	Expansion-Card Riser-Board Components and PCI Buses	142
	Disabling a Forgotten Password	144
7	Getting Help	147
	Technical Assistance	147
	Online Services	147
	AutoTech Service	148
	Automated Order-Status Service	148
	Technical Support Service	148
	Dell Enterprise Training and Certification	149
	Problems With Your Order	149
	Product Information	149
	Returning Items for Warranty Repair or Credit	149

Before You Call.	150
Contacting Dell.	152
Glossary	169
Index.	177

About Your System

This section describes the physical, firmware, and software interface features that provide and ensure the essential functioning of your system. The physical connectors on your system's front and back panels provide convenient connectivity and system expansion capability. The system firmware, applications, and operating systems monitor the system and component status and alert you when a problem arises. System conditions can be reported by any of the following:

- Front or back panel indicators
- System messages
- Warning messages
- Diagnostics messages
- Alert messages

This section describes each type of message, lists the possible causes, and provides steps to resolve any problems indicated by a message. The system indicators and features are illustrated in this section.

Other Information You May Need

 **CAUTION: The *Product Information Guide* provides important safety and regulatory information. Warranty information may be included within this document or as a separate document.**

- The *Rack Installation Guide* or *Rack Installation Instructions* included with your rack solution describes how to install your system into a rack.
- The *Getting Started Guide* provides an overview of system features, setting up your system, and technical specifications.
- CDs included with your system provide documentation and tools for configuring and managing your system.
- Systems management software documentation describes the features, requirements, installation, and basic operation of the software.
- Operating system documentation describes how to install (if necessary), configure, and use the operating system software.
- Documentation for any components you purchased separately provides information to configure and install these options.

- Updates are sometimes included with the system to describe changes to the system, software, and/or documentation.

 **NOTE:** Always check for updates on support.dell.com and read the updates first because they often supersede information in other documents.

- Release notes or readme files may be included to provide last-minute updates to the system or documentation or advanced technical reference material intended for experienced users or technicians.

Accessing System Features During Startup

Table 1-1 describes keystrokes that may be entered during startup to access system features. If your operating system begins to load before you enter the keystroke, allow the system to finish booting, and then restart your system and try again.

Table 1-1. Keystrokes for Accessing System Features

Keystroke	Description
<F2>	Enters the System Setup program. See "Using the System Setup Program" on page 38.
<F10>	Opens the utility partition, allowing you to run the system diagnostics. See "Running the System Diagnostics" on page 131
<Ctrl+E>	Enters the Baseboard Management Controller (BMC) Management Utility, which allows access to the system event log (SEL). See the <i>BMC User's Guide</i> for more information on setup and use of BMC.
<Ctrl+C>	Enters the SAS Configuration Utility. See your SAS adapter <i>User's Guide</i> for more information.
<Ctrl+R>	Enters the RAID configuration utility, which allows you to configure an optional RAID card. For more information, see the documentation for your RAID card.
<Ctrl+S>	Option is displayed only if you have PXE support enabled through the System Setup Program (see "Integrated Devices Screen" on page 42). This keystroke allows you to configure NIC settings for PXE boot. For more information, see the documentation for your integrated NIC.
<Ctrl+D>	If you have the optional Dell Remote Access Controller (DRAC), this keystroke allows access to selected DRAC configuration settings. See the DRAC User's Guide for more information on setup and use of DRAC.

Front-Panel Features and Indicators

Figure 1-1 shows the controls, indicators, and connectors located behind the optional rack bezel on the system's front panel.

Figure 1-1. Front-Panel Features and Indicators

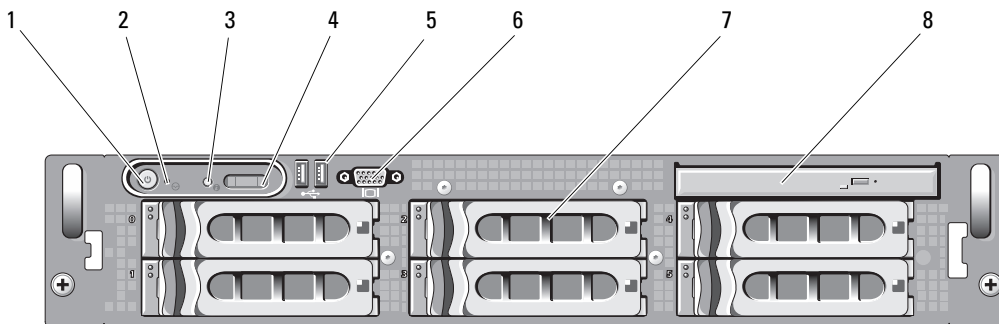

Table 1-2. Front-Panel LED Indicators, Buttons, and Connectors





Item	Indicator, Button, or Connector	Icon	Description
1	Power-on indicator, power button		<p>The power-on indicator lights when the system power is on.</p> <p>The power button controls the DC power supply output to the system.</p> <p>NOTE: If you turn off the system using the power button and the system is running an ACPI-compliant operating system, the system performs a graceful shutdown before the power is turned off. If the system is not running an ACPI-compliant operating system, the power is turned off immediately after the power button is pressed.</p>
2	NMI button		<p>Used to troubleshoot software and device driver errors when using certain operating systems. This button can be pressed using the end of a paper clip.</p> <p>Use this button only if directed to do so by qualified support personnel or by the operating system's documentation.</p>
3	System identification button		<p>The identification buttons on the front and back panels can be used to locate a particular system within a rack. When one of these buttons is pushed, the LCD panel on the front and the blue system status indicator on the back blink until one of the buttons is pushed again.</p>

Table 1-2. Front-Panel LED Indicators, Buttons, and Connectors (continued)

Item	Indicator, Button, or Connector	Icon	Description
4	LCD panel		<p>Provides system ID, status information, and system error messages.</p> <p>The LCD lights during normal system operation. Both the systems management software and the identification buttons located on the front and back of the system can cause the LCD to flash blue to identify a particular system.</p> <p>The LCD lights amber when the system needs attention, and the LCD panel displays an error code followed by descriptive text.</p> <p>NOTE: If the system is connected to AC power and an error has been detected, the LCD lights amber regardless of whether the system has been powered on.</p>
5	USB connectors (2)		Connects USB 2.0-compliant devices to the system.
6	Video connector		Connects a monitor to the system.
7	Hard drives (8)		Eight 2.5-inch hot plug OR Six 3.5-inch hot plug OR Four 3.5-inch hot-plug
8	Optical drive (optional)		One optional slimline IDE or DVD drive.

Hard-Drive Indicator Codes

The hard-drive carriers have two indicators—the drive-activity indicator and the drive-status indicator. See Figure 1-2. In RAID configurations, the drive-status indicator lights to indicate the status of the drive. In non-RAID configurations, only the drive-activity indicator lights; the drive-status indicator is off.

Figure 1-2. Hard-Drive Indicators

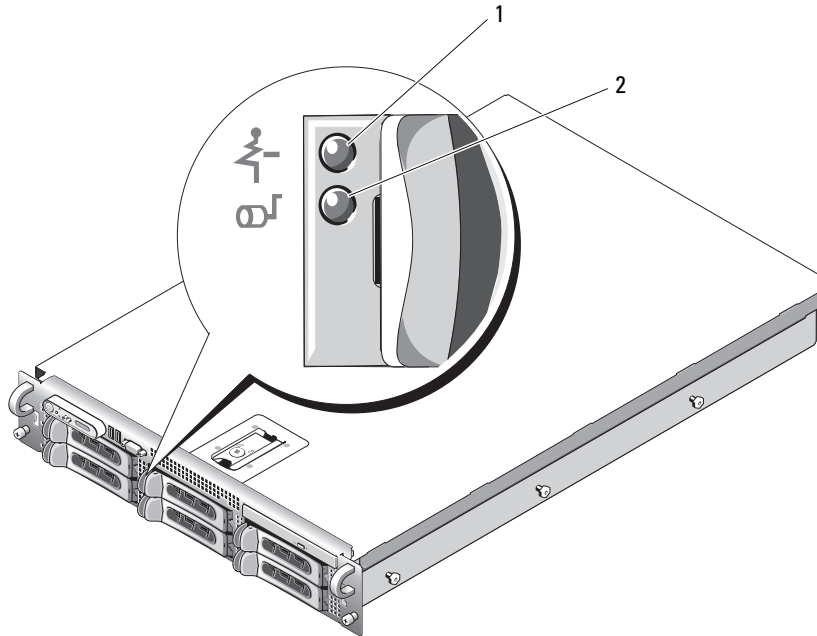

- | | | | |
|---|--|---|--------------------------------|
| 1 | drive-status indicator (green and amber) | 2 | green drive-activity indicator |
|---|--|---|--------------------------------|

Table 1-3 lists the drive indicator patterns for RAID hard drives. Different patterns are displayed as drive events occur in the system. For example, if a hard drive fails, the "drive failed" pattern appears. After the drive is selected for removal, the "drive being prepared for removal" pattern appears, followed by the "drive ready for insertion or removal" pattern. After the replacement drive is installed, the "drive being prepared for operation" pattern appears, followed by the "drive online" pattern.

 **NOTE:** For non-RAID configurations, only the drive-activity indicator is active. The drive-status indicator is off.

Table 1-3. Hard-Drive Indicator Patterns for RAID

Condition	Drive-Status Indicator Pattern
Identify drive/preparing for removal	Blinks green two times per second
Drive ready for insertion or removal	Off
Drive predicted failure	Blinks green, amber, and off.
Drive failed	Blinks amber four times per second.
Drive rebuilding	Blinks green slowly.
Drive online	Steady green.
Rebuild aborted	Blinks green three seconds, amber three seconds, and off six seconds.

Back-Panel Features and Indicators

Figure 1-3 shows the controls, indicators, and connectors located on the system's back panel.

Figure 1-3. Back-Panel Features and Indicators

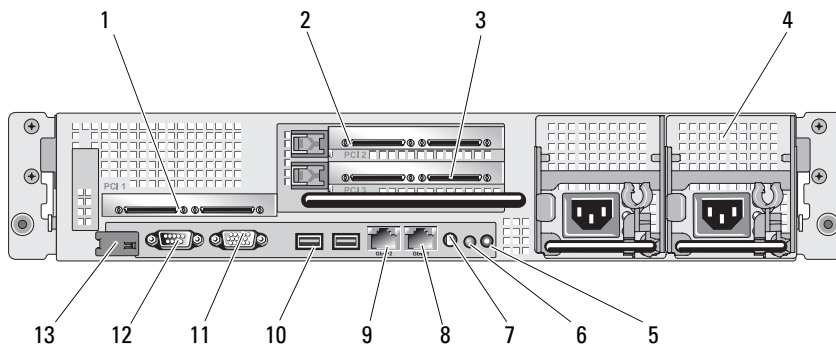

- | | | |
|--|--------------------------------|---------------------------|
| 1 center PCI riser (slot 1) | 2 left PCI riser (slot 2) | 3 left PCI riser (slot 3) |
| 4 power supplies (2) | 5 system identification button | 6 system status indicator |
| 7 system status indicator connector | 8 NIC2 connector | 9 NIC1 connector |
| 10 USB connectors (2) | 11 video connector | 12 serial connector |
| 13 remote access controller (optional) | | |

Connecting External Devices

When connecting external devices to your system, follow these guidelines:

- Most devices must be connected to a specific connector and device drivers must be installed before the device operates properly. (Device drivers are normally included with your operating system software or with the device itself.) See the documentation that accompanied the device for specific installation and configuration instructions.
- Always attach external devices while your system and the device are turned off. Next, turn on any external devices before turning on the system (unless the documentation for the device specifies otherwise).

For information about individual connectors, see "Jumpers and Connectors" on page 135. For information about enabling, disabling, and configuring I/O ports and connectors, see "Using the System Setup Program" on page 37.

Power Indicator Codes

The power button on the front panel controls the power input to the system's power supplies. The power indicator lights green when the system is on.

The indicators on the redundant power supplies show whether power is present or whether a power fault has occurred (see Figure 1-4). Table 1-4 lists the power supply indicator codes.

Table 1-4. Redundant Power Supply Indicators

Indicator	Function
Power supply status	Green indicates that the power supply is operational.
Power supply fault	Amber indicates a problem with the power supply.
AC line status	Green indicates that a valid AC source is connected to the power supply.

Figure 1-4. Redundant Power Supply Indicators

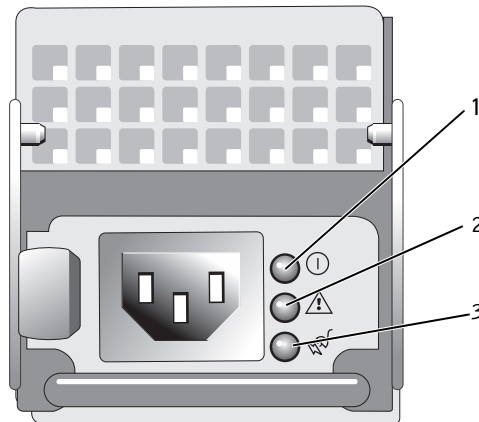

1 power supply status

2 power supply fault

3 AC line status

NIC Indicator Codes

Each NIC on the back panel has an indicator that provides information on network activity and link status. See Figure 1-5. Table 1-5 lists the NIC indicator codes.

Figure 1-5. NIC Indicators

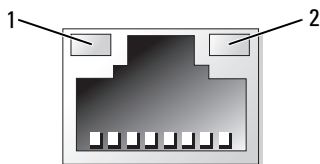

1 link indicator

2 activity indicator

Table 1-5. NIC Indicator Codes

Indicator	Indicator Code
Link and activity indicators are off	The NIC is not connected to the network.
Link indicator is green	The NIC is connected to a valid link partner on the network.
Activity indicator is amber blinking	Network data is being sent or received.

LCD Status Messages

The system's control panel LCD provides status messages to signify when the system is operating correctly or when the system needs attention.

The LCD lights blue to indicate a normal operating condition, and lights amber to indicate an error condition. The LCD scrolls a message that includes a status code followed by descriptive text. Table 1-6 lists the LCD status messages that can occur and the probable cause for each message. The LCD messages refer to events recorded in the System Event Log (SEL). For information on the SEL and configuring system management settings, see the systems management software documentation.

CAUTION: Only trained service technicians are authorized to remove the system cover and access any of the components inside the system. See your *Product Information Guide* for complete information about safety precautions, working inside the computer, and protecting against electrostatic discharge.

NOTE: If your system fails to boot, press the System ID button for at least five seconds until an error code appears on the LCD. Record the code, then see "Getting Help" on page 147.

Table 1-6. LCD Status Messages

Code	Text	Causes	Corrective Actions
N/A	<i>SYSTEM NAME</i>	A 62-character string that can be defined by the user in the System Setup program. The <i>SYSTEM NAME</i> displays under the following conditions: <ul style="list-style-type: none"> • The system is powered on. • The power is off and active POST errors are displayed. 	This message is for information only. You can change the system ID and name in the System Setup program. See "Using the System Setup Program" on page 37.
E1000	FAILSAFE, Call Support		See "Getting Help" on page 147.
E1114	Temp Ambient	Ambient system temperature is out of acceptable range.	See "Troubleshooting System Cooling Problems" on page 119.
E1116	Temp Memory	Memory has exceeded acceptable temperature and has been disabled to prevent damage to the components.	See "Troubleshooting System Cooling Problems" on page 119.
E12nn	xx PwrGd	Specified voltage regulator has failed.	See "Getting Help" on page 147.
E1210	CMOS Batt	CMOS battery is missing, or the voltage is out of acceptable range.	See "Troubleshooting the System Battery" on page 118.
E1211	ROMB Batt	RAID battery is either missing, bad, or unable to recharge due to thermal issues.	Reseat the RAID battery connector. See "RAID Battery" on page 74, and "Troubleshooting System Cooling Problems" on page 119.
E1229	CPU # VCORE	Processor # VCORE voltage regulator has failed.	See "Getting Help" on page 147.
E1310	RPM Fan ##	RPM of specified cooling fan is out of acceptable operating range.	See "Troubleshooting System Cooling Problems" on page 119.
E1313	Fan Redundancy	The system is no longer fan-redundant. Another fan failure will put the system at risk of overheating.	Check control panel LCD for additional scrolling messages. See "Troubleshooting System Cooling Problems" on page 119.

Table 1-6. LCD Status Messages (continued)

Code	Text	Causes	Corrective Actions
E1410	CPU # IERR	Specified microprocessor is reporting an internal error.	See your system's <i>Information Update Tech Sheet</i> located on support.dell.com for the most current system information. If problem persists, see "Getting Help" on page 147.
E1414	CPU # Thermtrip	Specified microprocessor is out of acceptable temperature range and has halted operation.	See "Troubleshooting System Cooling Problems" on page 119. If the problem persists, ensure that the microprocessor heat sinks are properly installed. See "Troubleshooting the Microprocessors" on page 128. NOTE: The LCD continues to display this message until the system's power cord is disconnected and reconnected to the AC power source, or the SEL is cleared using either Server Assistant or the BMC Management Utility. See the <i>Dell OpenManage Baseboard Management Controller User's Guide</i> for information about these utilities.
E1418	CPU # Presence	Specified processor is missing or bad, and the system is in an unsupported configuration.	See "Troubleshooting the Microprocessors" on page 128.
E141C	CPU Mismatch	Processors are in a configuration unsupported by Dell.	Ensure that your processors match and conform to the type described in the Microprocessor Technical Specifications outlined in your system's <i>Getting Started Guide</i> .
E141F	CPU Protocol	The system BIOS has reported a processor protocol error.	See "Getting Help" on page 147.
E1420	CPU Bus PERR	The system BIOS has reported a processor bus parity error.	See "Getting Help" on page 147.
E1421	CPU Init	The system BIOS has reported a processor initialization error.	See "Getting Help" on page 147.

Table 1-6. LCD Status Messages (continued)

Code	Text	Causes	Corrective Actions
E1422	CPU Machine Chk	The system BIOS has reported a machine check error.	See "Getting Help" on page 147.
E1610	PS # Missing	No power is available from the specified power supply; specified power supply is improperly installed or faulty.	See "Troubleshooting Power Supplies" on page 118.
E1614	PS # Status	No power is available from the specified power supply; specified power supply is improperly installed or faulty.	See "Troubleshooting Power Supplies" on page 118.
E1618	PS # Predictive	Power supply voltage is out of acceptable range; specified power supply is improperly installed or faulty.	See "Troubleshooting Power Supplies" on page 118.
E161C	PS # Input Lost	Power source for specified power supply is unavailable, or out of acceptable range.	Check the AC power source for the specified power supply. If problem persists, see "Troubleshooting Power Supplies" on page 118.
E1620	PS # Input Range	Power source for specified power supply is unavailable, or out of acceptable range.	Check the AC power source for the specified power supply. If problem persists, see "Troubleshooting Power Supplies" on page 118.
E1624	PS Redundancy	The power supply subsystem is no longer redundant. If the last supply fails, the system will go down.	See "Troubleshooting Power Supplies" on page 118.
E1710	I/O Channel Chk	The system BIOS has reported an I/O channel check.	See "Getting Help" on page 147.

Table 1-6. LCD Status Messages (continued)

Code	Text	Causes	Corrective Actions
E1711	PCI PERR B## D## F## PCI PERR Slot #	The system BIOS has reported a PCI parity error on a component that resides in PCI configuration space at bus ##, device ##, function ##. The system BIOS has reported a PCI parity error on a component that resides in the specified PCI slot.	Remove and reseat the PCI expansion cards. If the problem persists, see "Troubleshooting Expansion Cards" on page 127. Reinstall the expansion-card cage. See "Expansion-Card Cage" on page 78. If the problem persists, the riser card or system board is faulty. See "Getting Help" on page 147.
E1712	PCI SERR B## D## F## PCI SERR Slot #	The system BIOS has reported a PCI system error on a component that resides in PCI configuration space at bus ##, device ##, function ##. The system BIOS has reported a PCI system error on a component that resides in the specified slot.	Remove and reseat the PCI expansion cards. If the problem persists, see "Troubleshooting Expansion Cards" on page 127. Reinstall the expansion-card cage. See "Expansion-Card Cage" on page 78. If the problem persists, the riser card or system board is faulty. See "Getting Help" on page 147.
E1714	Unknown Err	The system BIOS has determined that there has been an error in the system, but is unable to determine its origin.	See "Getting Help" on page 147.
E171F	PCIE Fatal Err B## D## F## PCIE Fatal Err Slot #	The system BIOS has reported a PCIe fatal error on a component that resides in PCI configuration space at bus ##, device ##, function ##. The system BIOS has reported a PCIe fatal error on a component that resides in the specified slot.	Remove and reseat the PCI expansion cards. If the problem persists, see "Troubleshooting Expansion Cards" on page 127. Reinstall the expansion-card cage. See "Expansion-Card Cage" on page 78. If the problem persists, the riser card or system board is faulty. See "Getting Help" on page 147.
E1810	HDD ## Fault	The SAS subsystem has determined that hard drive ## has experienced a fault.	See "Troubleshooting a Hard Drive" on page 124.

Table 1-6. LCD Status Messages (continued)

Code	Text	Causes	Corrective Actions
E1811	HDD ## Rbld Abrt	The specified hard drive has experienced a rebuild abort.	See "Troubleshooting a Hard Drive" on page 124. If the problem persists, see your RAID documentation.
E1812	HDD ## Removed	The specified hard drive has been removed from the system.	Information only.
E1913	CPU & Firmware Mismatch	The BMC firmware does not support the CPU.	Update to the latest BMC firmware. See the <i>BMC User's Guide</i> for more information on setup and use of BMC.
E1A11	PCI Rsr Config	PCI risers are not configured correctly; some invalid configurations may prevent the system from powering on.	See "Expansion-Card Riser Boards" on page 98.
E1A12	PCI Rsr Missing	One or all of the PCI risers is missing, preventing the system from powering on.	Information only.
E1A14	SAS Cable A	SAS cable A is missing or bad.	Reseat the cable. If problem persists, replace cable. See "SAS Controller Daughter Card" on page 69.
E1A15	SAS Cable B	SAS cable B is missing or bad.	Reseat the cable. If problem persists, replace cable. See "SAS Controller Daughter Card" on page 69.
E2010	No Memory	No memory is installed in the system.	Install memory. See "Installing Memory Modules" on page 90.
E2011	Mem Config Err	Memory detected, but is not configurable. Error detected during memory configuration.	See "Troubleshooting System Memory" on page 120.
E2012	Unusable Memory	Memory is configured, but not usable. Memory subsystem failure.	See "Troubleshooting System Memory" on page 120.
E2013	Shadow BIOS Fail	The system BIOS failed to copy its flash image into memory.	See "Troubleshooting System Memory" on page 120.
E2014	CMOS Fail	CMOS failure. CMOS RAM not functioning properly.	See "Getting Help" on page 147.
E2015	DMA Controller	DMA controller failure.	See "Getting Help" on page 147.

Table 1-6. LCD Status Messages (continued)

Code	Text	Causes	Corrective Actions
E2016	Int Controller	Interrupt controller failure.	See "Getting Help" on page 147.
E2017	Timer Fail	Timer refresh failure.	See "Getting Help" on page 147.
E2018	Prog Timer	Programmable interval timer error.	See "Getting Help" on page 147.
E2019	Parity Error	Parity error.	See "Getting Help" on page 147.
E201A	SIO Err	SIO failure.	See "Getting Help" on page 147.
E201B	Kybd Controller	Keyboard controller failure.	See "Getting Help" on page 147.
E201C	SMI Init	System management interrupt (SMI) initialization failure.	See "Getting Help" on page 147.
E201D	Shutdown Test	BIOS shutdown test failure.	See "Getting Help" on page 147.
E201E	POST Mem Test	BIOS POST memory test failure.	See "Troubleshooting System Memory" on page 120. If problem persists, see "Getting Help" on page 147.
E201F	DRAC Config	Dell remote access controller (DRAC) configuration failure.	Check screen for specific error messages. Ensure that DRAC cables and connectors are properly seated. If problem persists, see your DRAC documentation.
E2020	CPU Config	CPU configuration failure.	Check screen for specific error messages.
E2021	Memory Population	Incorrect memory configuration. Memory population order incorrect.	Check screen for specific error messages. See "Troubleshooting System Memory" on page 120.
E2022	POST Fail	General failure after video.	Check screen for specific error messages.
E2110	MBE Crd # DIMM ## & ##	One of the DIMMs in the set implicated by "## & ##" has had a memory multi-bit error (MBE). If no memory card is present, the "Crd #" string is left out of the message.	See "Troubleshooting System Memory" on page 120.

Table 1-6. LCD Status Messages (continued)

Code	Text	Causes	Corrective Actions
E2111	SBE Log Disable Crd # DIMM ##	The system BIOS has disabled memory single-bit error (SBE) logging, and will not resume logging further SBEs until the system is rebooted. "##" represents the DIMM implicated by the BIOS. If no memory riser card is present, the "Crd #" string is left out of the message.	See "Troubleshooting System Memory" on page 120.
E2112	Mem Spare Crd # DIMM ##	The system BIOS has spared the memory because it has determined that the memory had too many errors. "## & ##" represents the DIMM pair implicated by the BIOS. If no memory card is present, the "Crd #" string is left out of the message.	See "Troubleshooting System Memory" on page 120.
E2113	Mem Mirror Crd # DIMM ## & ##	The system BIOS has disabled memory mirroring because it has determined that one half of the mirror has had too many errors. "## & ##" represents the DIMM pair implicated by the BIOS. If no memory card is present, the "Crd #" string is left out of the message.	See "Troubleshooting System Memory" on page 120.
E2118	Fatal NB Mem CRC	One of the connections in the Fully Buffered DIMM (FBD) memory subsystem link on the Northbound side has failed.	See "Troubleshooting System Memory" on page 120.
E2119	Fatal SB Mem CRC	One of the connections in the FBD memory subsystem link on the Southbound side has failed.	See "Troubleshooting System Memory" on page 120.
I1910	Intrusion	System cover has been removed.	Information only.
I1911	>3 ERRs Chk Log	LCD overflow message. A maximum of three error messages can display sequentially on the LCD. The fourth message displays as the standard overflow message.	Check the SEL for details on the events.

Table 1-6. LCD Status Messages (continued)

Code	Text	Causes	Corrective Actions
I1912	SEL Full	System Event Log is full of events, and is unable to log any more events.	Clear the log by deleting event entries.
W1228	ROMB Batt < 24hr	Warns predictively that the RAID battery has less than 24 hours of charge left.	Replace RAID battery. See "RAID Battery" on page 74.

NOTE: For the full name of an abbreviation or acronym used in this table, see the "Glossary" on page 169.

Solving Problems Described by LCD Status Messages

The code and text on the LCD can often specify a very precise fault condition that is easily corrected. For example, if the code `E1418 CPU_1_Presence` appears, you know that a microprocessor is not installed in socket 1.

In contrast, you might be able to determine the problem if multiple related errors occur. For example, if you receive a series of messages indicating multiple voltage faults, you might determine that the problem is a failing power supply.

Removing LCD Status Messages

For faults associated with sensors, such as temperature, voltage, fans, and so on, the LCD message is automatically removed when that sensor returns to a normal state. For example, if temperature for a component goes out of range, the LCD displays the fault; when the temperature returns to the acceptable range, the message is removed from the LCD. For other faults, you must take action to remove the message from the display:

- Clear the SEL — You can perform this task remotely, but you will lose the event history for the system.
- Power cycle — Turn off the system and disconnect it from the electrical outlet; wait approximately ten seconds, reconnect the power cable, and restart the system.

Any of these actions will remove fault messages, and return the status indicators and LCD colors to the normal state. Messages will reappear under the following conditions:

- The sensor returns to a normal state but fails again, resulting in a new SEL entry.
- The system is reset and new error events are detected.
- A failure is recorded from another source that maps to the same display entry.

System Messages

System messages appear on the screen to notify you of a possible problem with the system. Table 1-3 lists the system messages that can occur and the probable cause and corrective action for each message.

 **NOTE:** If you receive a system message that is not listed in Table 1-3, check the documentation for the application that is running when the message appears or the operating system's documentation for an explanation of the message and recommended action.

 **CAUTION:** Only trained service technicians are authorized to remove the system cover and access any of the components inside the system. See your *Product Information Guide* for complete information about safety precautions, working inside the computer, and protecting against electrostatic discharge.

Table 1-7. System Messages

Message	Causes	Corrective Actions
Alert! Redundant memory disabled! Memory configuration does not support redundant memory.	Installed memory modules are not the same type and size; faulty memory module(s).	Ensure that all memory modules are of the same type and size and that they are properly installed. If the problem persists, see "Troubleshooting System Memory" on page 120.
Attempting to update Remote Configuration. Please wait...	Remote Configuration request has been detected and is being processed.	Wait until the process is complete.
BIOS Update Attempt Failed!	Remote BIOS update attempt failed.	Retry the BIOS update. If problem persists, see "Getting Help" on page 147.
Caution! NVRAM_CLR jumper is installed on system board.	NVRAM_CLR jumper is installed. CMOS has been cleared.	Remove NVRAM_CLR jumper. See Figure 6-1 for jumper location.
CPUs with different cache sizes detected!	Microprocessors with different cache sizes are installed.	Ensure that all microprocessors have the same cache size and that they are properly installed. See "Processors" on page 93.
Decreasing available memory	Faulty or improperly installed memory modules.	See "Troubleshooting System Memory" on page 120.
DIMM pairs must be matched in size, speed, and technology. The following DIMM pair is mismatched: DIMM x and DIMM y.	Mismatched or unmatched DIMMs installed; faulty or improperly seated memory module(s).	Ensure that all pairs of memory modules are of the same type and size and that they are properly installed. See "System Memory" on page 89. If the problem persists, see "Troubleshooting System Memory" on page 120.

Table 1-7. System Messages (continued)

Message	Causes	Corrective Actions
DIMMs must be populated in sequential order beginning with slot 1. The following DIMM is electrically isolated: DIMM x.	The specified DIMM is inaccessible to the system due to its location. DIMMs must be populated in sequential order, beginning with slot 1.	Populate 2, 4, or 8 DIMMs sequentially beginning with slot 1. See "System Memory" on page 89.
DIMMs should be installed in pairs. Pairs must be matched in size, speed, and technology.	Mismatched or unmatched DIMMs installed; faulty or improperly seated memory module(s). The system will operate in a degraded mode with reduced ECC protection. Only memory installed in channel 0 will be accessible.	Ensure that all pairs of memory modules are of the same type and size and that they are properly installed. See "System Memory" on page 89. If the problem persists, see "Troubleshooting System Memory" on page 120.
Dual-rank DIMM paired with Single-rank DIMM - The following DIMM/rank has been disabled by BIOS: DIMM x Rank y	Mismatched DIMMs installed; faulty memory module(s). The system has detected a dual-rank DIMM paired with a single-rank DIMM. The second rank of the dual-rank DIMM will be disabled.	Ensure that all pairs of memory modules are of the same type and size and that they are properly installed. See "System Memory" on page 89. If the problem persists, see "Troubleshooting System Memory" on page 120.
Diskette drive n seek failure	<p>Incorrect configuration settings in the System Setup program.</p> <p>Faulty or improperly installed diskette drive.</p> <p>Loose tape drive interface cable, or loose power cable.</p>	<p>Run the System Setup program to correct the settings. See "Using the System Setup Program" on page 37.</p> <p>Replace the diskette. If the problem persists, see "Troubleshooting a Diskette Drive" on page 121.</p> <p>Reseat tape drive interface cable, or power cable. If the problem persists, see "Troubleshooting a Diskette Drive" on page 121.</p>
Diskette read failure	Faulty or improperly inserted diskette or tape drive.	Replace the diskette. See "Troubleshooting a Diskette Drive" on page 121.
Diskette subsystem reset failed	Faulty or improperly installed diskette or tape drive.	Replace the diskette or tape. If the problem persists, see "Troubleshooting a Diskette Drive" on page 121.
Drive not ready	Diskette missing from or improperly inserted in diskette drive.	Replace the diskette. If the problem persists, see "Troubleshooting a Diskette Drive" on page 121.

Table 1-7. System Messages (continued)

Message	Causes	Corrective Actions
Error: Incorrect memory configuration. DIMMs must be installed in pairs of matched memory size, speed, and technology.	Mismatched or unmatched DIMMs installed; faulty or improperly seated memory module(s).	Ensure that all pairs of memory modules are of the same type and size and that they are properly installed. See "System Memory" on page 89. If the problem persists, see "Troubleshooting System Memory" on page 120.
Error: Memory failure detected. Memory size reduced. Replace the faulty DIMM as soon as possible.	Faulty or improperly seated memory module(s).	See "Troubleshooting System Memory" on page 120.
!!*** Error: Remote Access Controller initialization failure*** RAC virtual USB devices may not be available...	Remote Access Controller initialization failure	Ensure that the Remote Access Controller is properly installed. See "Installing a RAC Card" on page 80.
FBD training error: The following branch has been disabled: Branch x	The specified branch (channel pair) contains DIMMs that are incompatible with each other.	Ensure that only Dell-qualified memory is used. Dell recommends purchasing memory upgrade kits directly from www.dell.com or your Dell sales agent to ensure compatibility.
Gate A20 failure	Faulty keyboard controller; faulty system board.	See "Getting Help" on page 147.
General failure	The operating system is unable to carry out the command.	This message is usually followed by specific information. Note the information, and take the appropriate action to resolve the problem.
Invalid NVRAM configuration, Resource Re-allocated	System detected and corrected a resource conflict.	No action is required.
Keyboard Controller failure	Faulty keyboard controller; faulty system board	See "Getting Help" on page 147.
Manufacturing mode detected	System is in manufacturing mode.	Reboot to take the system out of manufacturing mode.
MEMBIST failure - The following DIMM/rank has been disabled by BIOS: DIMM x Rank y	Faulty memory module(s).	See "Troubleshooting System Memory" on page 120.

Table 1-7. System Messages (continued)

Message	Causes	Corrective Actions
Memory address line failure at <i>address</i> , read <i>value</i> expecting <i>value</i>	Faulty or improperly installed memory modules.	See "Troubleshooting System Memory" on page 120.
Memory double word logic failure at <i>address</i> , read <i>value</i> expecting <i>value</i>		
Memory odd/even logic failure at <i>address</i> , read <i>value</i> expecting <i>value</i>		
Memory write/read failure at <i>address</i> , read <i>value</i> expecting <i>value</i>		
Memory tests terminated by keystroke.	POST memory test terminated by pressing the spacebar.	Information only.
No boot device available	Faulty or missing optical/diskette drive subsystem, hard drive, or hard-drive subsystem, or no boot disk in drive A.	Use a bootable diskette, CD, or hard drive. If the problem persists, see "Troubleshooting a Diskette Drive" on page 121, "Troubleshooting an Optical Drive" on page 123, and "Troubleshooting a Hard Drive" on page 124. See "Using the System Setup Program" on page 37 for information on setting the order of boot devices.
No boot sector on hard drive	Incorrect configuration settings in System Setup program, or no operating system on hard drive.	Check the hard-drive configuration settings in the System Setup program. See "Using the System Setup Program" on page 37. If necessary, install the operating system on your hard drive. See your operating system documentation.
No timer tick interrupt	Faulty system board.	See "'Getting Help" on page 147."
Northbound merge error - The following DIMM has been disabled by BIOS: DIMM x	The specified DIMM was unable to establish a successful data link with the memory controller.	See "Troubleshooting System Memory" on page 120.
Not a boot diskette	No operating system on diskette.	Use a bootable diskette.

Table 1-7. System Messages (continued)

Message	Causes	Corrective Actions
PCIe Degraded Link Width Error: Embedded Bus# <i>nn</i> /Dev# <i>nn</i> /Func <i>n</i> Expected Link Width is <i>n</i> Actual Link Width is <i>n</i>	Faulty or improperly installed PCIe card in the specified slot.	Reseat the PCIe card in the specified slot number. See "Expansion Cards" on page 76. If the problem persists, see "Getting Help" on page 147.
PCIe Degraded Link Width Error: Slot <i>n</i> Expected Link Width is <i>n</i> Actual Link Width is <i>n</i>	Faulty or improperly installed PCIe card in the specified slot.	Reseat the PCIe card in the specified slot number. See "Expansion Cards" on page 76. If the problem persists, see "Getting Help" on page 147.
PCIe Training Error: Embedded Bus# <i>nn</i> /Dev# <i>nn</i> /Func <i>n</i> PCIe Training Error: Slot <i>n</i>	Faulty or improperly installed PCIe card in the specified slot.	Reseat the PCIe card in the specified slot number. See "Expansion Cards" on page 76. If the problem persists, see "Getting Help" on page 147.
PCI BIOS failed to install	PCI device BIOS (Option ROM) checksum failure is detected during shadowing. Loose cables to expansion card(s); faulty or improperly installed expansion card(s).	Reseat the expansion card(s). Ensure that all appropriate cables are securely connected to the expansion card(s). If the problem persists, see "Troubleshooting Expansion Cards" on page 127.
Plug & Play Configuration Error	Error encountered in initializing PCI device; faulty system board.	Install the NVRAM_CLR jumper and reboot the system. See Figure 6-1 for jumper location. If the problem persists, see "Troubleshooting Expansion Cards" on page 127.
Read fault Requested sector not found	The operating system cannot read from the diskette or hard drive, the system could not find a particular sector on the disk, or the requested sector is defective.	Replace the diskette. Ensure that the diskette and hard drive cables are properly connected. See "Troubleshooting a USB Device" on page 115, or "Troubleshooting a Hard Drive" on page 124 for the appropriate drive(s) installed in your system.
Remote configuration update attempt failed	System unable to process Remote Configuration request	Retry Remote Configuration.

Table 1-7. System Messages (continued)

Message	Causes	Corrective Actions
ROM bad checksum = address	Expansion card improperly installed or faulty.	Reseat the expansion card(s). Ensure that all appropriate cables are securely connected to the expansion card(s). If the problem persists, see "Troubleshooting Expansion Cards" on page 127.
Sector not found Seek error Seek operation failed	Faulty diskette or hard drive.	See "Troubleshooting a Diskette Drive" on page 121, "Troubleshooting a USB Device" on page 115, or "Troubleshooting a Hard Drive" on page 124 for the appropriate drive(s) installed in your system.
Shutdown failure	Shutdown test failure.	See "Troubleshooting System Memory" on page 120.
The amount of system memory has changed	Memory has been added or removed or a memory module may be faulty.	If memory has been added or removed, this message is informative and can be ignored. If memory has not been added or removed, check the SEL to determine if single-bit or multi-bit errors were detected and replace the faulty memory module. See "Troubleshooting System Memory" on page 120.
Time-of-day clock stopped	Faulty battery or faulty chip.	See "Troubleshooting the System Battery" on page 118.
The following DIMM pair is not compatible with the memory controller: DIMM x and DIMM y	The specified DIMM(s) are incompatible with the system.	Ensure that only Dell-qualified memory is used. Dell recommends purchasing memory upgrade kits directly from www.dell.com or your Dell sales agent to ensure compatibility.
The following DIMMs are not compatible: DIMM x and DIMM y	The specified DIMM(s) are incompatible with the system.	Ensure that only ECC FBD1 memory is used. Dell recommends purchasing memory upgrade kits directly from www.dell.com or your Dell sales agent to ensure compatibility.
Time-of-day not set - please run SETUP program	Incorrect Time or Date settings; faulty system battery.	Check the Time and Date settings. See "Using the System Setup Program" on page 37. If the problem persists, replace the system battery. See "System Battery" on page 96.

Table 1-7. System Messages (continued)

Message	Causes	Corrective Actions
Timer chip counter 2 failed	Faulty system board.	See "Getting Help" on page 147.
Unsupported CPU combination Unsupported CPU stepping detected	Microprocessor(s) is not supported by the system.	Install a supported microprocessor or microprocessor combination. See "Processors" on page 93.
Utility partition not available	The <F10> key was pressed during POST, but no utility partition exists on the boot hard drive.	Create a utility partition on the boot hard drive. See the CDs that came with your system.
Warning! No micro code update loaded for processor 0	Micro code update failed.	Update the BIOS firmware. See "Getting Help" on page 147.
Warning: Embedded RAID firmware is not present.	Embedded RAID firmware does not respond.	See the RAID controller documentation for information about installing or updating the RAID firmware.
Warning: Embedded RAID error.	Embedded RAID firmware responds with an error.	See "Troubleshooting a SAS or SAS RAID Controller Daughter Card" on page 126. See the RAID controller documentation for information about installing or updating the RAID firmware.
Warning: The current memory configuration is not optimal. Dell recommends a population of 2, 4, or 8 DIMMs. DIMMs should be populated sequentially starting in slot 1.	System has detected a legal but non-optimal population of DIMMs (for example, 1 DIMM, 6 DIMMs, 4 DIMMs in slots 1, 2, 5, and 6, etc.). The system will run with all memory accessible but will experience sub-optimal performance.	Populate 2, 4, or 8 DIMMs sequentially beginning with slot 1. See "System Memory" on page 89.
Write fault Write fault on selected drive	Faulty diskette, optical/diskette drive assembly, hard drive, or hard-drive subsystem.	See "Troubleshooting a Diskette Drive" on page 121, "Troubleshooting an Optical Drive" on page 123, and "Troubleshooting a Hard Drive" on page 124.

NOTE: For the full name of an abbreviation or acronym used in this table, see the "Glossary" on page 169.

Warning Messages

A warning message alerts you to a possible problem and prompts you to respond before the system continues a task. For example, before you format a diskette, a message will warn you that you may lose all data on the diskette. Warning messages usually interrupt the task and require you to respond by typing *y* (yes) or *n* (no).



NOTE: Warning messages are generated by either the application or the operating system. For more information, see the documentation that accompanied the operating system or application.

Diagnostics Messages

When you run system diagnostics, an error message may result. Diagnostic error messages are not covered in this section. Record the message on a copy of the Diagnostics Checklist in "Getting Help" on page 147, and then follow the instructions in that section for obtaining technical assistance.

Alert Messages

Systems management software generates alert messages for your system. Alert messages include information, status, warning, and failure messages for drive, temperature, fan, and power conditions. For more information, see the systems management software documentation.

Using the System Setup Program

After you set up your system, run the System Setup program to familiarize yourself with your system configuration and optional settings. Record the information for future reference.

You can use the System Setup program to:

- Change the system configuration stored in NVRAM after you add, change, or remove hardware
- Set or change user-selectable options—for example, the time or date
- Enable or disable integrated devices
- Correct discrepancies between the installed hardware and configuration settings

Entering the System Setup Program

- 1 Turn on or restart your system.
- 2 Press <F2> immediately after you see the following message:

<F2> = System Setup

If your operating system begins to load before you press <F2>, allow the system to finish booting, and then restart your system and try again.

 **NOTE:** To ensure an orderly system shutdown, see the documentation that accompanied your operating system.

Responding to Error Messages

You can enter the System Setup program by responding to certain error messages. If an error message appears while the system is booting, make a note of the message. Before entering the System Setup program, see "System Messages" on page 28 for an explanation of the message and suggestions for correcting errors.

 **NOTE:** After installing a memory upgrade, it is normal for your system to send a message the first time you start your system.

Using the System Setup Program

Table 2-1 lists the keys that you use to view or change information on the System Setup program screens and to exit the program.

Table 2-1. System Setup Program Navigation Keys

Keys	Action
Up arrow or <Shift><Tab>	Moves to the previous field.
Down arrow or <Tab>	Moves to the next field.
Spacebar, <+>, <->, left and right arrows	Cycles through the settings in a field. In many fields, you can also type the appropriate value.
<Esc>	Exits the System Setup program and restarts the system if any changes were made.
<F1>	Displays the System Setup program's help file.



NOTE: For most of the options, any changes that you make are recorded but do not take effect until you restart the system.

System Setup Options

Main Screen

When you enter the System Setup program, the main System Setup program screen appears (see Figure 2-1).

Figure 2-1. Main System Setup Program Screen

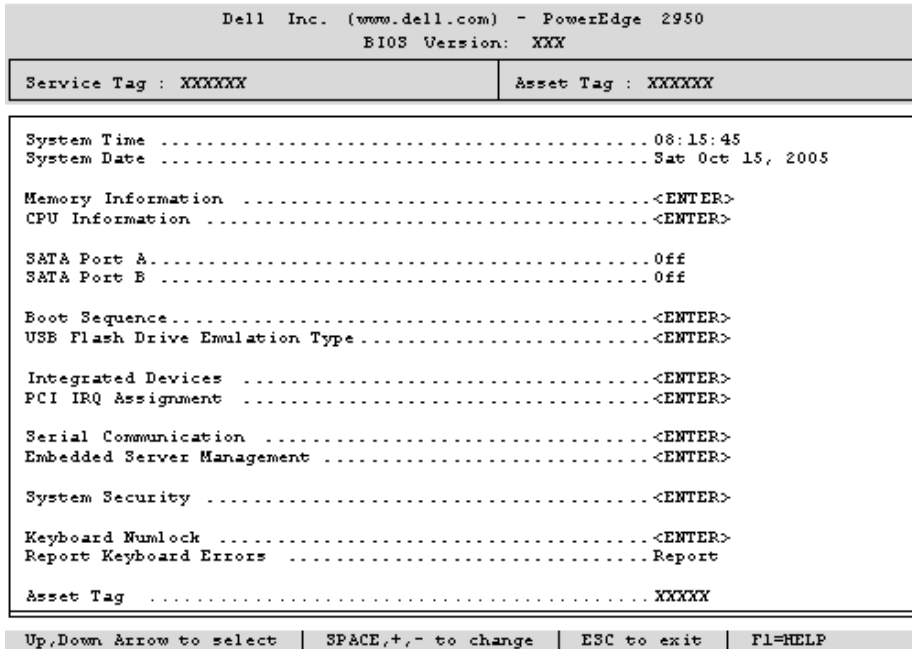

Table 2-2 lists the options and descriptions for the information fields that appear on the main System Setup program screen.



NOTE: The options for the System Setup program change based on the system configuration.



NOTE: The System Setup program defaults are listed under their respective options, where applicable.

Table 2-2. System Setup Program Options

Option	Description
System Time	Resets the time on the system's internal clock.
System Date	Resets the date on the system's internal calendar.
Memory Information	Displays information related to installed system, video, and redundant memory, including size, type, and speed.
CPU Information	Displays information related to microprocessors (speed, cache size, and so on). Enable or disable Hyper-Threading technology by changing the setting of the Logical Processor option. See Table 2-3.
SATA Port X	Displays type and capacity of SATA drive attached to Port X.

Table 2-2. System Setup Program Options (continued)

Option	Description
Boot Sequence	Determines the order in which the system searches for boot devices during system startup. Available options can include the diskette drive, CD drive, hard drives, and network. If you have installed a RAC, additional options such as virtual floppy and virtual CD-ROM may be present. NOTE: System boot is not supported from an external device attached to a SAS or SCSI adapter. See support.dell.com for the latest support information about booting from external devices
USB Flash Drive Type (Auto default)	Determines the emulation type for a USB flash drive. Hard disk allows the USB flash drive to act as a hard drive. Floppy allows the USB flash drive to act as a removal diskette drive. Auto automatically chooses an emulation type.
Integrated Devices	See Table 2-4.
PCI IRQ Assignment	Displays a screen to change the IRQ assigned to each of the integrated devices on the PCI bus, and any installed expansion cards that require an IRQ.
Serial Communication	Displays a screen to configure serial communication, external serial connector, fail-safe baud rate, remote terminal type, and redirection after boot.
Embedded Server Management	Displays a screen to configure the front-panel LCD options and to set a user-defined LCD string.
System Security	Displays a screen to configure the system password and setup password features. See Table 2-6. For further information, see "Using the System Password" on page 45 and "Using the Setup Password" on page 47.
Keyboard NumLock (On default)	Determines whether your system starts up with the NumLock mode activated on 101- or 102-key keyboards (does not apply to 84-key keyboards).
Report Keyboard Errors (Report default)	Enables or disables reporting of keyboard errors during the POST. Select Report for host systems that have keyboards attached. Select Do Not Report to suppress all error messages relating to the keyboard or keyboard controller during POST. This setting does not affect the operation of the keyboard itself if a keyboard is attached to the system.
Asset Tag	Displays the customer-programmable asset tag number for the system if an asset tag number has been assigned.

CPU Information Screen

Table 2-3 lists the options and descriptions for the information fields that appear on the **CPU Information** screen.

Table 2-3. CPU Information Screen

Option	Description
Bus Speed	Displays the bus speed of the processors.
Logical Processor (Enabled default)	Displays when the processors support HyperThreading. Enabled permits all logical processors to be used by the operating system. Only the first logical processor of each processor installed in the system is used by the operating system if Disabled is selected.
Adjacent Cache Line Prefetch (Enabled default)	Enables or disables optimal use of sequential memory access. Disable this option for applications that require high use of random memory access.
Virtualization Technology (Disabled default)	Displays when the processor(s) support Virtualization Technology. Enabled permits virtualization software to utilize Virtualization Technology functions incorporated in the processor design. This feature can only be used by software that supports Virtualization Technology.
Hardware Prefetcher (Enabled default)	Enables or disables the hardware prefetcher.
Demand-Based Power Management (Disabled default)	Enables or disables demand-based power management. When enabled, the CPU Performance State tables will be reported to the operating system; when disabled, the CPU Performance State tables will not be reported to the operating system. If any of the CPUs do not support demand-based power management, the field will become read-only, and automatically set to Disabled .
Processor X ID	Displays the family and model number of each processor. A submenu displays processor core speed, amount of level 2 cache, and number of cores.

Integrated Devices Screen

Table 2-4 lists the options and descriptions for the information fields that appear on the **Integrated Devices** screen.

Table 2-4. Integrated Devices Screen Options

Option	Description
Integrated SAS Controller (Enabled default)	Enables or disables the integrated SAS controller.
Embedded SATA (Off default)	Allows the integrated SATA controller to be set to Off or ATA Mode .
IDE CD-ROM Controller (Auto default)	Enables the integrated IDE controller. When set to Auto , each channel of the integrated IDE controller is enabled if IDE devices are attached to the channel and the external IDE controller is not detected. NOTE: This CD-ROM option will not appear on this menu screen if your system does not include this optional device.
User Accessible USB Ports (All Ports On default)	Enables or disables the system's user accessible USB ports. Options are All Ports On , Only Back Ports On , and All Ports Off .
Embedded Gb NIC1 (Enabled with PXE default)	Enables or disables the system's integrated NIC. Options are Enabled without PXE , Enabled with PXE , and Disabled . PXE support allows the system to boot from the network. Changes take effect after the system reboots.
MAC Address	Displays the MAC address for the integrated 10/100/1000 NIC. This field does not have user-selectable settings.
TOE Capability	Displays the TCP/IP offload engine (TOE) feature status of the onboard NIC.
Embedded Gb NIC2 (Enabled with PXE default)	Enables or disables the system's integrated NIC. Options are Enabled without PXE , Enabled with PXE , and Disabled . PXE support allows the system to boot from the network. Changes take effect after the system reboots.
MAC Address	Displays the MAC address for the integrated 10/100/1000 NIC. This field does not have user-selectable settings.
TOE Capability	Displays the TCP/IP offload engine (TOE) feature status of the onboard NIC.
Diskette Controller (Auto default)	Enables or disables the system's diskette drive controller. When Auto is selected, the system turns off the controller when necessary to accommodate a controller card installed in an expansion slot. You can also configure the drive as Read-Only , or Off . When using the Read-Only setting, the drive cannot be used to write to a disk.

Serial Communication Screen

Table 2-5 lists the options and descriptions for the information fields that appear on the **Serial Communication** screen.

Table 2-5. Serial Communication Screen Options

Option	Description
Serial Communication (Off default)	Options are On with Console Redirection via COM2, and Off .
Failsafe Baud Rate (57600 default)	Displays the failsafe baud rate used for console redirection when the baud rate cannot be negotiated automatically with the remote terminal. This rate should not be adjusted.
Remote Terminal Type (VT 100/VT 220 default)	Select either VT 100/VT 220 or ANSI .
Redirection After Boot (Enabled default)	Enables or disables BIOS console redirection after your system boots to the operating system.

System Security Screen

Table 2-6 lists the options and descriptions for the information fields that appear on the **System Security** screen.

Table 2-6. System Security Screen Options

Option	Description
System Password	Displays the current status of your system's password security feature and allows you to assign and verify a new system password. NOTE: See "Using the System Password" on page 45 for instructions on assigning a system password and using or changing an existing system password.
Setup Password	Restricts access to the System Setup program in the same way that you restrict access to your system using the system password feature. NOTE: See "Using the Setup Password" on page 47 for instructions on assigning a setup password and using or changing an existing setup password.

Table 2-6. System Security Screen Options (continued)

Option	Description
Password Status	<p>Setting the Setup Password option to Enabled prevents the system password from being changed or disabled at system start-up.</p> <p>To <i>lock</i> the system password, assign a setup password in the Setup Password option and then change the Password Status option to Locked. In this state, you cannot change the system password using the System Password option and cannot be disabled at system start-up by pressing <Ctrl><Enter>.</p> <p>To <i>unlock</i> the system password, enter the setup password in the Setup Password field and then change the Password Status option to Unlocked. In this state, you can disable the system password at system start-up by pressing <Ctrl><Enter> and then change the password using the System Password option.</p>
Power Button (Enabled default)	<p>Turns system's power off and on.</p> <ul style="list-style-type: none">• If you turn off the system using the power button and the system is running an ACPI-compliant operating system, the system can perform an orderly shutdown before power is turned off.• If the system is not running an ACPI-compliant operating system, power is turned off immediately after the power button is pressed. <p>The button is enabled in the System Setup program. When disabled, the button can only turn on system power.</p> <p>NOTE: You can still turn on the system by using the power button, even if the Power Button option is set to Disabled.</p>
NMI Button (Disabled default)	<p> NOTICE: Use the NMI button only if directed to do so by qualified support personnel or by the operating system's documentation. Pressing this button halts the operating system and displays a diagnostic screen.</p> <p>Sets the NMI feature On or Off.</p>
AC Power Recovery (Last default)	<p>Determines how the system reacts when power is restored to the system. If system is set to Last, the system returns to the last power state. On turns on the system after power is restored. When set to Off, the system remains off after power is restored.</p>

Exit Screen

After you press <Esc> to exit the System Setup program, the **Exit** screen displays the following options:

- Save Changes and Exit
- Discard Changes and Exit
- Return to Setup

System and Setup Password Features

- ➔ **NOTICE:** The password features provide a basic level of security for the data on your system. If your data requires more security, use additional forms of protection, such as data encryption programs.
- ➔ **NOTICE:** Anyone can access the data stored on your system if you leave the system running and unattended without having a system password assigned or if you leave your system unlocked so that someone can disable the password by changing a jumper setting.

Your system is shipped to you without the system password feature enabled. If system security is a concern, operate your system only with system password protection.

To change or delete an existing password, you must know the password (see "Deleting or Changing an Existing System Password" on page 47). If you forget your password, you cannot operate your system or change settings in the System Setup program until a trained service technician changes the password jumper setting to disable the passwords, and erases the existing passwords. This procedure is described in "Disabling a Forgotten Password" on page 144.

Using the System Password

After a system password is assigned, only those who know the password have full use of the system. When the **System Password** option is set to **Enabled**, the system prompts you for the system password after the system starts.

Assigning a System Password

Before you assign a system password, enter the System Setup program and check the **System Password** option.

When a system password is assigned, the setting shown for the **System Password** option is **Enabled**. If the setting shown for the **Password Status** is **Unlocked**, you can change the system password. If the **Password Status** option is **Locked**, you cannot change the system password. When the system password feature is disabled by a jumper setting, the system password is **Disabled**, and you cannot change or enter a new system password.

When a system password is not assigned and the password jumper on the system board is in the enabled (default) position, the setting shown for the **System Password** option is **Not Enabled** and the **Password Status** field is **Unlocked**. To assign a system password:

- 1 Verify that the **Password Status** option is set to **Unlocked**.
- 2 Highlight the **System Password** option and press <Enter>.
- 3 Type your new system password.

You can use up to 32 characters in your password.

As you press each character key (or the spacebar for a blank space), a placeholder appears in the field.

The password assignment is not case-sensitive. However, certain key combinations are not valid. If you enter one of these combinations, the system beeps. To erase a character when entering your password, press <Backspace> or the left-arrow key.

 **NOTE:** To escape from the field without assigning a system password, press <Enter> to move to another field, or press <Esc> at any time prior to completing step 5.

4 Press <Enter>.

5 To confirm your password, type it a second time and press <Enter>.

The setting shown for the **System Password** changes to **Enabled**. Exit the System Setup program and begin using your system.

6 Either reboot your system now for your password protection to take effect or continue working.

 **NOTE:** Password protection does not take effect until you reboot the system.

Using Your System Password to Secure Your System

 **NOTE:** If you have assigned a setup password (see "Using the Setup Password" on page 47), the system accepts your setup password as an alternate system password.

When the **Password Status** option is set to **Unlocked**, you have the option to leave the password security enabled or to disable the password security.

To leave the password security enabled:

1 Turn on or reboot your system by pressing <Ctrl><Alt>.

2 Type your password and press <Enter>.

To disable the password security:

1 Turn on or reboot your system by pressing <Ctrl><Alt>.

2 Type your password and press <Ctrl><Enter>.

When the **Password Status** option is set to **Locked** whenever you turn on your system or reboot your system by pressing <Ctrl><Alt>, type your password and press <Enter> at the prompt.

After you type the correct system password and press <Enter>, your system operates as usual.

If an incorrect system password is entered, the system displays a message and prompts you to re-enter your password. You have three attempts to enter the correct password. After the third unsuccessful attempt, the system displays an error message showing the number of unsuccessful attempts and that the system has halted and will shut down. This message can alert you to an unauthorized person attempting to use your system.

Even after you shut down and restart the system, the error message continues to be displayed until the correct password is entered.

 **NOTE:** You can use the **Password Status** option in conjunction with the **System Password** and **Setup Password** options to further protect your system from unauthorized changes.

Deleting or Changing an Existing System Password

- 1 When prompted, press <Ctrl><Enter> to disable the existing system password.
If you are asked to enter your setup password, contact your network administrator.
- 2 Enter the System Setup program by pressing <F2> during POST.
- 3 Select the System Security screen field to verify that the Password Status option is set to Unlocked.
- 4 When prompted, type the system password.
- 5 Confirm that Not Enabled is displayed for the System Password option.

If Not Enabled is displayed for the System Password option, the system password has been deleted. If Enabled is displayed for the System Password option, press the <Alt> key combination to restart the system, and then repeat steps 2 through 5.

Using the Setup Password

Assigning a Setup Password

You can assign (or change) a setup password only when the Setup Password option is set to Not Enabled. To assign a setup password, highlight the Setup Password option and press the <+> or <-> key. The system prompts you to enter and verify the password. If a character is illegal for password use, the system beeps.



NOTE: The setup password can be the same as the system password. If the two passwords are different, the setup password can be used as an alternate system password. However, the system password cannot be used in place of the setup password.

You can use up to 32 characters in your password.

As you press each character key (or the spacebar for a blank space), a placeholder appears in the field.

The password assignment is not case-sensitive. However, certain key combinations are not valid. If you enter one of these combinations, the system beeps. To erase a character when entering your password, press <Backspace> or the left-arrow key.

After you verify the password, the Setup Password setting changes to Enabled. The next time you enter the System Setup program, the system prompts you for the setup password.

A change to the Setup Password option becomes effective immediately (restarting the system is not required).

Operating With a Setup Password Enabled

If Setup Password is set to Enabled, you must enter the correct setup password before you can modify most of the System Setup options. When you start the System Setup program, the program prompts you to enter a password.

If you do not enter the correct password in three attempts, the system lets you view, but not modify, the System Setup screens—with the following exception: If **System Password** is not set to **Enabled** and is not locked through the **Password Status** option, you can assign a system password (however, you cannot disable or change an existing system password).

 **NOTE:** You can use the **Password Status** option in conjunction with the **Setup Password** option to protect the system password from unauthorized changes.

Deleting or Changing an Existing Setup Password

- 1 Enter the System Setup program and select the **System Security** option.
- 2 Highlight the **Setup Password** option, press <Enter> to access the setup password window, and press <Enter> twice to clear the existing setup password.

The setting changes to **Not Enabled**.

- 3 If you want to assign a new setup password, perform the steps in "Assigning a Setup Password" on page 47.

Disabling a Forgotten Password

See "Disabling a Forgotten Password" on page 144.

Baseboard Management Controller Configuration

The Baseboard Management Controller (BMC) enables configuring, monitoring, and recovery of systems remotely. BMC provides the following features:

- Uses the system's integrated NIC
- Fault logging and SNMP alerting
- Access to system event log and sensor status
- Control of system functions including power on and off
- Support is independent of the system's power or operating state
- Provides text console redirection for system setup, text-based utilities, and operating system consoles

 **NOTE:** To remotely access the BMC through the integrated NIC, you must connect the network connection to integrated NIC1.

For additional information on using BMC, see the documentation for the BMC and systems management applications.

Entering the BMC Setup Module

- 1 Turn on or restart your system.
- 2 Press <Ctrl-E> when prompted after POST.
If your operating system begins to load before you press <Ctrl-E>, allow the system to finish booting, and then restart your system and try again.

BMC Setup Module Options

For information about the BMC Setup Module options and how to configure the emergency management port (EMP), see the *BMC User's Guide*.

Installing System Components

This section describes how to install the following system components:

- Hard drives
- Power supplies
- System fans
- Cooling shroud
- Fan brackets
- SAS controller daughter card
- RAID battery
- Expansion cards
- Expansion card cage
- RAC card
- Optical, diskette, and tape drives
- System memory
- Processors
- System battery
- Expansion-card riser boards
- Sideplane board
- SAS Backplane board
- Control panel assembly
- System board

Recommended Tools

You may need the following items to perform the procedures in this section:

- Key to the system keylock
- #1 and #2 Phillips screwdrivers
- T-10 Torx driver
- Wrist grounding strap

Inside the System

CAUTION: Only trained service technicians are authorized to remove the system cover and access any of the components inside the system. See your *Product Information Guide* for complete information about safety precautions, working inside the computer, and protecting against electrostatic discharge.

In Figure 3-1, the bezel and system cover are removed to provide an interior view of the system.

Figure 3-1. Inside the System

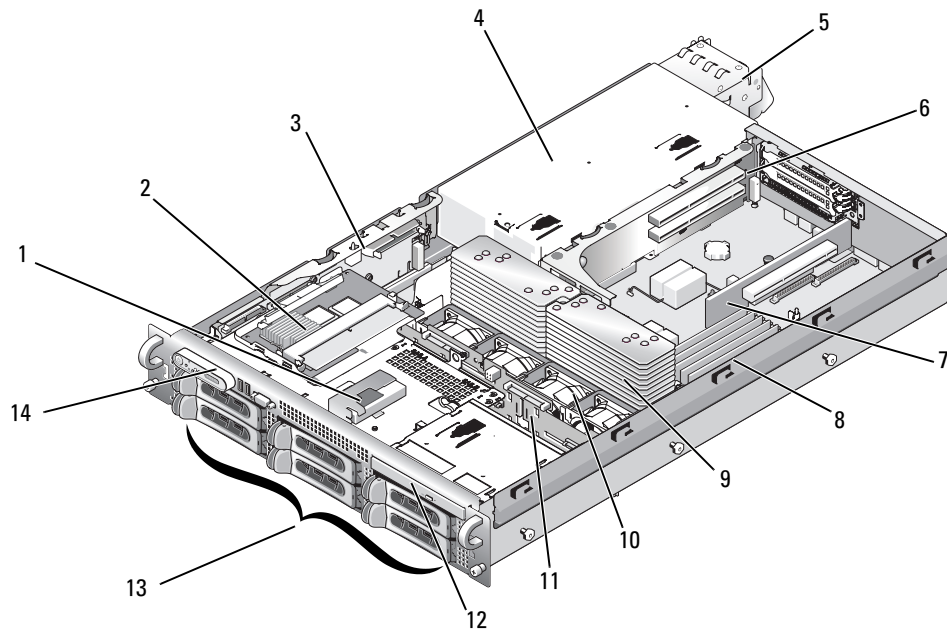

- | | | |
|--|--|--------------------------------------|
| 1 RAID battery (optional) | 2 SAS controller daughter card or SAS RAID controller daughter card (optional) | 3 sideplane |
| 4 power supply bay | 5 power supplies (2) | 6 left riser |
| 7 central riser | 8 memory modules (8) | 9 heatsinks and microprocessors (2) |
| 10 hot-pluggable fans (4) | 11 SAS backplane | 12 slimline optical drive (optional) |
| 13 SAS or SATA hard drives (up to 8, depending on configuration) | 14 control panel | |

The system board holds the system's control circuitry and other electronic components. Several hardware options, such as the microprocessors and memory, are installed directly on the system board. The expansion-card cage containing the left riser accommodates up to two full-length PCIe or PCI-X expansion cards, while the central riser accommodates one half-length PCIe expansion card.

The system provides space for an optional optical drive. The optical drive connects to the controllers on the system board through the sideplane board. For more information, see "Optical Drive" on page 81.

Depending on the hard drive configuration you ordered, an optional 3.5-inch diskette drive, and an optional tape drive may also be available for installation into a media bay. See Table 3-1 for configuration options.

Table 3-1. Hard Drive and Media Bay Configurations

Number of Hard Drives on Backplane	Hard-Drive Size	Media Bay
6	3.5-inch	No
4	3.5-inch	Yes
8	2.5-inch	Yes

The hard-drive bays provide space for up to eight 2.5-inch SAS drives or six 3.5-inch SAS or SATA hard drives. The hard drives connect to a RAID controller card through the SAS backplane board. For more information, see "Hard Drives" on page 55 and "SAS Controller Daughter Card" on page 69.

During an installation or troubleshooting procedure, you may be required to change a jumper setting. For more information, see "System Board Jumpers" on page 135.

Front Bezel

A lock on the bezel restricts access to the power button, diskette drive, optical drive, and hard drive(s). A control panel LCD located on the front panel and accessible through the front bezel displays the system's status.

Removing the Front Bezel

- 1 Using the system key, unlock the bezel.
- 2 Press the tab at the left end of the bezel.
- 3 Rotate the left end of the bezel away from the system to release the right end of the bezel.
- 4 Pull the bezel away from the system. See Figure 3-2.

Figure 3-2. Removing the Front Bezel

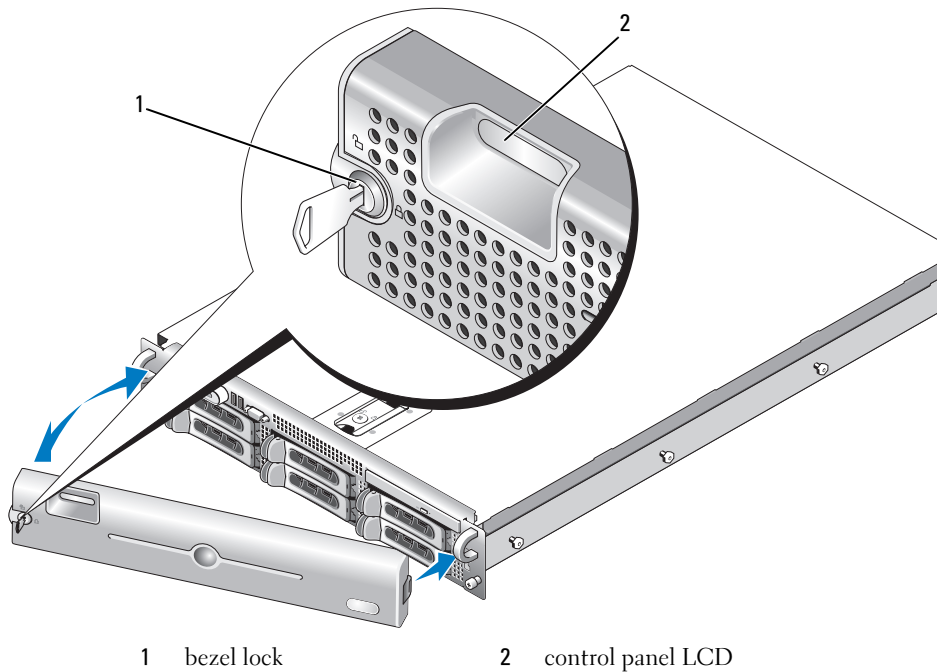

Replacing the Front Bezel

To replace the front bezel, perform the above steps in reverse.

Opening and Closing the System

⚠ CAUTION: Only trained service technicians are authorized to remove the system cover and access any of the components inside the system. See your *Product Information Guide* for complete information about safety precautions, working inside the computer, and protecting against electrostatic discharge.

Opening the System

To upgrade or troubleshoot the system, remove the system cover to gain access to internal components.

- 1 Unless you are installing a hot-plug component such as a cooling fan or power supply, turn off the system and attached peripherals, and disconnect the system from the electrical outlet and peripherals.
- 2 To remove the system cover, turn the latch release lock counter-clockwise to the unlocked position. See Figure 3-3.
- 3 Lift up on the latch on top of the system. See Figure 3-3.
- 4 Grasp the cover on both sides and carefully lift the cover away from the system.

Closing the System

- 1 Lift up the latch on the cover.
- 2 Place the cover on top of the system and offset the cover slightly back so that it clears the chassis J hooks and lays flush on the system chassis. See Figure 3-3.
- 3 Push down the latch to lever the cover into the closed position.
- 4 Rotate the latch release lock in a clockwise direction to secure the cover.

Figure 3-3. Removing the Cover

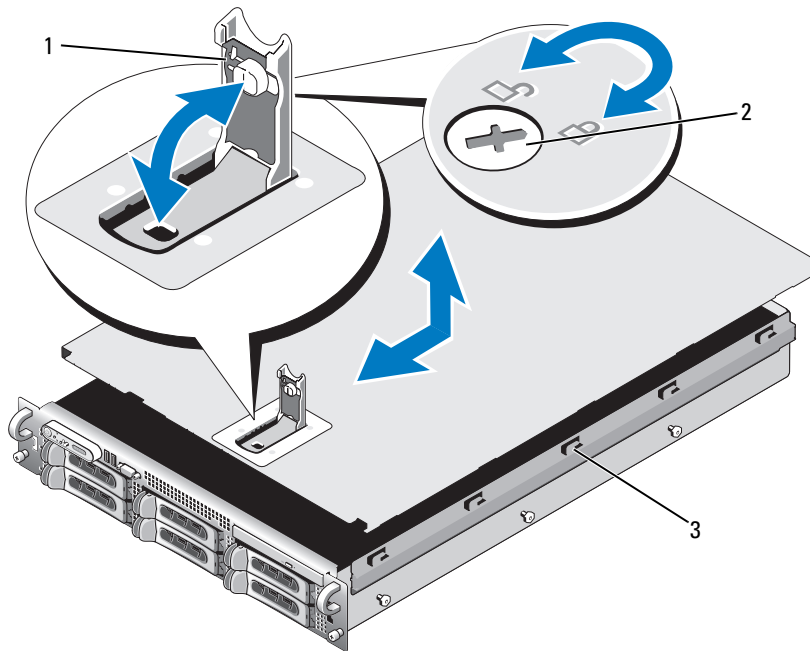

1 latch

2 latch release lock

3 alignment J hooks

Hard Drives

This subsection describes how to install and configure SAS or SATA hard drives in the system's internal hard-drive bays. Your system features up to six 3.5-inch hard drives, or eight 2.5-inch hard drives. All drives connect to the system board through one of three optional SAS backplane boards. See "SAS Backplane Board Connectors" on page 139 for information on these backplane options.

NOTE: Depending on the hard drive configuration you ordered, your hard drive(s) may come with a drive interposer that allows your SATA drive to attach to the SAS connector on the backplane.

Before You Begin

Hard drives are supplied in special hot-pluggable drive carriers that fit in the hard-drive bays. Depending on your configuration, you received one of the following two drive carrier types:

- SATA drive carrier — Usable only with a SATA hard drive.
- SATAu drive carrier — Usable with either a SAS hard drive or a SATA hard drive with a universal interposer card. The interposer card provides enhanced functionality that makes the SATA hard drive usable in some storage systems.

 **NOTICE:** Before attempting to remove or install a drive while the system is running, see the documentation for the optional SAS RAID controller daughter card to ensure that the host adapter is configured correctly to support hot-plug drive removal and insertion.

 **NOTE:** It is recommended that you use only drives that have been tested and approved for use with the SAS backplane board.

You may need to use different programs than those provided with the operating system to partition and format SAS or SATA hard drives.

 **NOTICE:** Do not turn off or reboot your system while the drive is being formatted. Doing so can cause a drive failure.

When you format a high-capacity hard drive, allow enough time for the formatting to be completed. Long format times for these drives are normal. A 9-GB hard drive, for example, can take up to 2.5 hours to format.

Removing a Drive Blank

 **NOTICE:** To maintain proper system cooling, all empty hard-drive bays must have drive blanks installed. If you remove a hard-drive carrier from the system and do not reinstall it, you must replace the carrier with a drive blank.

The process for removing a drive blank depends on whether your system is configured with 3.5-inch or 2.5-inch hard drives.

For 3.5-inch hard drive configurations:

- 1 Remove the front bezel, if attached. See "Removing the Front Bezel" on page 53.
- 2 Insert your finger under the shrouded end of the blank and press in on the latch to eject the blank outward from the bay.
- 3 Pry the ends of the blank outward until the blank is free.

For 2.5-inch hard drive configurations, remove the blank as you would the 2.5-inch hard drive carrier:

- 1 Remove the front bezel, if attached. See "Removing the Front Bezel" on page 53.
- 2 Open the drive blank release handle to release the blank. See Figure 3-4.
- 3 Slide the drive blank out until it is free of the drive bay.

Installing a Drive Blank

The process for installing a drive blank depends on whether your system is configured with 3.5-inch or 2.5-inch hard drives.

For 3.5-inch hard drive configurations, the drive blank is keyed to ensure correct insertion into the drive bay. To install a 3.5-inch drive blank, insert and rotate in the keyed side of the blank into the drive bay and press evenly on the other end of the blank until it is fully inserted and latched.

For 2.5-inch hard drive configurations, install the hard drive blank as a 2.5-inch hard drive carrier:

- 1 Remove the front bezel, if attached. See "Removing the Front Bezel" on page 53.
- 2 Open the handle on the drive blank.
- 3 Insert the drive blank into the drive bay until the blank is fully seated.
- 4 Close the handle to lock the blank in place.
- 5 Replace the front bezel, if it was removed in step 1.

Removing a Hot-Plug Hard Drive

- 1 Remove the front bezel, if attached. See "Removing the Front Bezel" on page 53.
- 2 From the RAID management software, prepare the drive for removal and wait until the hard-drive indicators on the drive carrier signal that the drive can be removed safely. See your SAS RAID controller documentation for information about hot-plug drive removal.
If the drive has been online, the green activity/fault indicator will flash as the drive is powered down. When both drive indicators are off, the drive is ready for removal.
- 3 Open the drive carrier release handle to release the drive. See Figure 3-4.
- 4 Slide the hard drive out until it is free of the drive bay.
- 5 If you do not replace the hard drive, insert a drive blank in the vacated drive bay. See "Installing a Drive Blank" on page 57.

 **NOTICE:** To maintain proper system cooling, all empty hard-drive bays must have drive blanks installed.

Installing a Hot-Plug Hard Drive

 **NOTICE:** When installing a hard drive, ensure that the adjacent drives are fully installed. Inserting a hard-drive carrier and attempting to lock its handle next to a partially installed carrier can damage the partially installed carrier's shield spring and make it unusable.

 **NOTICE:** Not all operating systems support hot-plug drive installation. See the documentation supplied with your operating system.

- 1 Remove the front bezel, if attached. See "Removing the Front Bezel" on page 53.
- 2 If a drive blank is present in the bay, remove it. See "Removing a Drive Blank" on page 56.
- 3 Install the hot-plug hard drive.
 - a Open the handle on the hard-drive carrier.

Figure 3-4. Installing a Hot-Plug Hard Drive

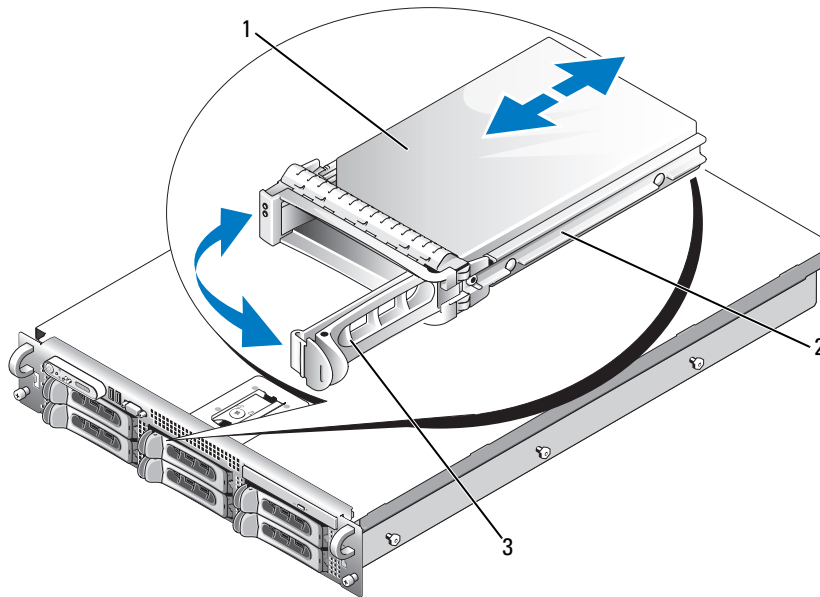

- 1 hard drive 2 drive carrier 3 drive carrier release handle

- b** Insert the hard-drive carrier into the drive bay until the carrier contacts the backplane.
 - c** Close the handle to lock the drive in place.
- 4** Replace the front bezel, if it was removed in step 1.

Replacing a Hard-Drive Carrier

Removing a Hard Drive From a Hard-Drive Carrier

- 1** If you are removing a SATA hard drive from a SATAu drive carrier, remove the interposer card:
 - a** Viewing the hard drive carrier from the rear, locate the release lever on the left end of the interposer card.
 - b** Push the lever away from the carrier rail to release the left end of the card.
 - c** Rotate the left end away from the hard drive to release the connector.
 - d** Pull the right end of the interposer card clear of the slots in the carrier rail.
- 2** Remove the four screws from the slide rails on the hard-drive carrier and separate the hard drive from the carrier.

Installing a SAS Hard Drive Into a SATAu Drive Carrier

NOTE: SAS hard drives must be installed only in SATAu drive carriers. The SATAu drive carrier is labeled "SATAu" and also has marks indicating the SAS and SATA mounting screws.

- 1 Insert the SAS hard drive into the hard-drive carrier with the connector end of the drive at the rear. See Figure 3-5.
- 2 Viewing the assembly as shown in Figure 3-5, align the bottom rear screw hole on the hard drive with the hole labeled "SAS" on the hard drive carrier.
When aligned correctly, the rear of the hard drive will be flush with the rear of the hard-drive carrier.
- 3 Attach the four screws to secure the hard drive to the hard-drive carrier. See Figure 3-5.

Figure 3-5. Installing a SAS Hard Drive Into a SATAu Drive Carrier

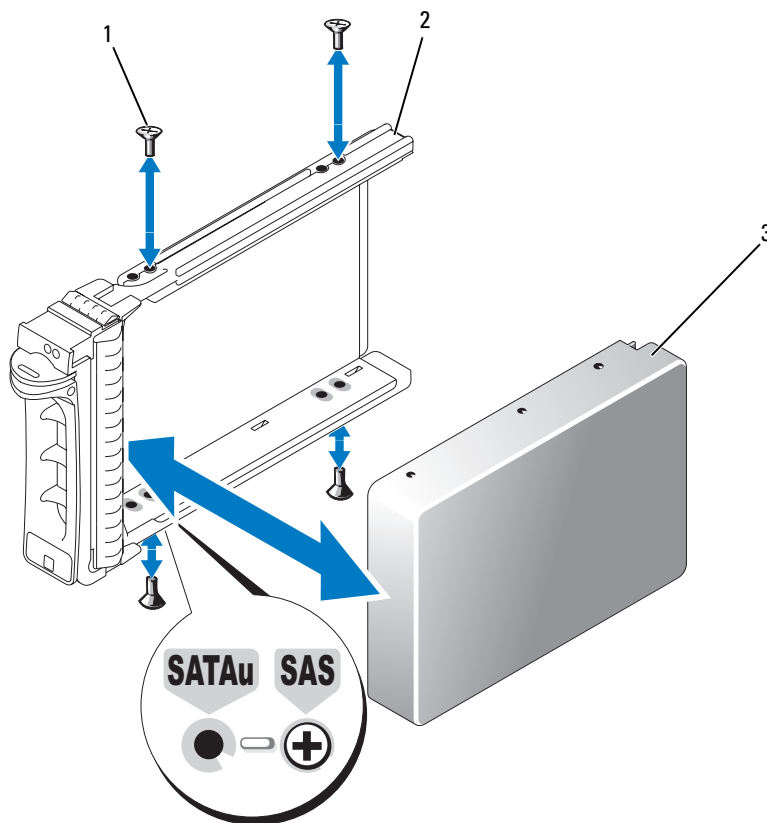

1 screws (4)

2 SATAu drive carrier

3 SAS hard drive

Installing a SATA Hard Drive Into a SATA Drive Carrier

NOTE: SATA hard drives that connect directly to the SAS backplane must be installed in SATA drive carriers (labeled "SATA"). Only SATA hard drives with interposer cards can be installed in SATAu drive carriers.

- 1 Insert the SATA hard drive into the hard-drive carrier with the connector end of the drive at the rear. See Figure 3-6.
- 2 Align the screw holes on the hard drive with the holes on the hard-drive carrier. See Figure 3-6.
- 3 Attach the four screws to secure the hard drive to the hard-drive carrier. See Figure 3-6.

Figure 3-6. Installing a SATA Hard Drive Into a SATA Drive Carrier

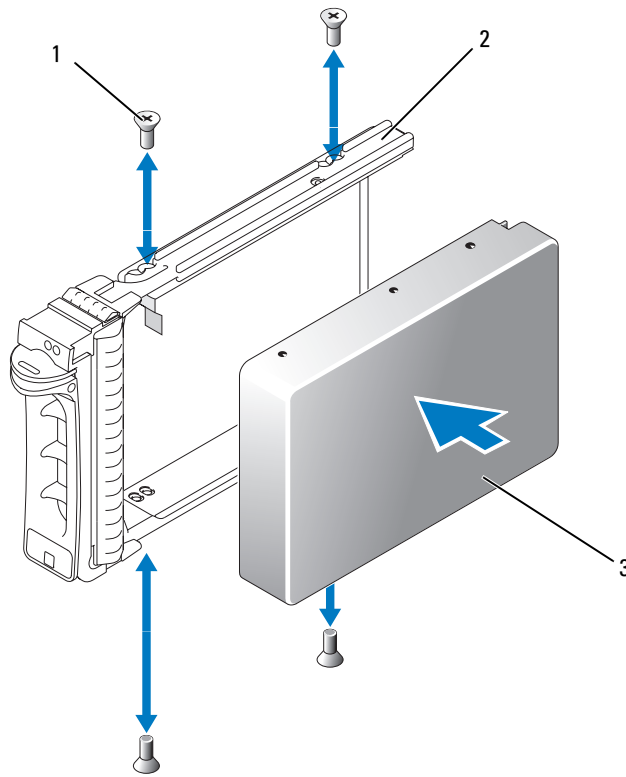

1 screws (4)

2 SATA drive carrier

3 SATA hard drive

Installing a SATA Hard Drive and Interposer Card Into a SATAu Hard-Drive Carrier

 **NOTE:** When you install a SATA hard drive into a SATAu drive carrier, you must install an interposer card onto the back of the hard drive. The SATAu drive carrier is labeled "SATAu" and also has marks indicating the SAS and SATA mounting screws.

- 1** Insert the SATA hard drive into the SATAu hard-drive carrier with the connector end of the drive at the rear. See Figure 3-7.
- 2** Viewing the assembly as shown in Figure 3-7, align the bottom rear screw hole on the hard drive with the hole labeled "SATAu" on the hard drive carrier.

When aligned correctly, the rear of the interposer will be flush with the rear of the hard-drive carrier.

- 3** Attach the four screws to secure the hard drive to the hard-drive carrier. See Figure 3-7.
- 4** Attach the interposer card to the rear of the SATA hard drive:
 - a** Angle the top of the interposer card into the inside top carrier rail so that the tabs on the interposer card bracket attach to the slots on the inside of the carrier rail. See Figure 3-7.
 - b** Rotate the bottom end of the card toward the hard drive to seat the connector. See Figure 3-7.
 - c** Push the bottom end of the card to the hard drive until the latch on the card bracket clicks into place.

Figure 3-7. Installing a SATA Hard Drive and Interposer Card Into a SATAu Drive Carrier

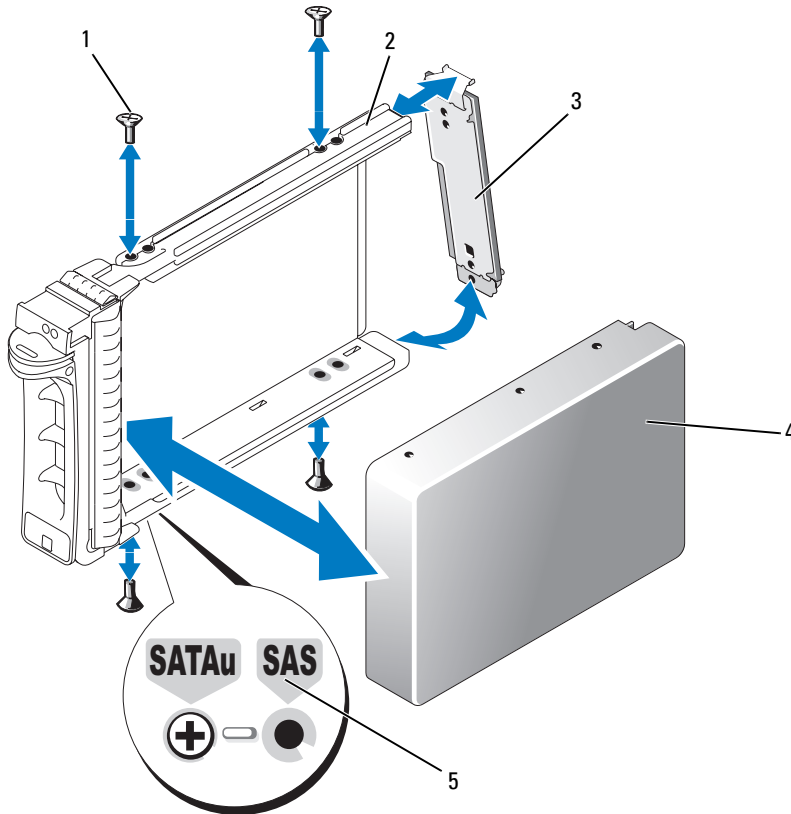

- | | | | | | |
|---|-----------------|---|---------------------|---|-----------------------------|
| 1 | screws (4) | 2 | SATAu drive carrier | 3 | interposer card (SATA only) |
| 4 | SATA hard-drive | 5 | hole labels | | |

Power Supplies

Your system supports one or two power supplies rated at an output of 750 W. If only one power supply is installed, it must be installed in the left power supply bay (1). If two power supplies are installed, the second power supply serves as a redundant, hot-plug power source.

NOTICE: To ensure proper system cooling, the power supply blank must be installed on the unoccupied power supply bay in a non-redundant configuration. See "Installing the Power Supply Blank" on page 65.

Removing a Power Supply





-  **NOTICE:** The system requires one power supply for the system to operate normally. The system is in the redundant mode when two power supplies are installed and both power supplies are connected to an AC power source. Remove and replace only one power supply at a time in a system that is powered on. Operating the system with only one power supply installed and without a power supply blank installed for extended periods of time can cause the system to overheat.
 -  **NOTICE:** If only one power supply is installed, it must be installed in the left power supply bay (1).
 -  **NOTICE:** If you connect the system to a power source in the range of 120 to 220 VAC, and if two power supplies are installed, the second power supply serves as a redundant, hot-plug power source.
 -  **NOTE:** On your rack system, you may have to unlatch and lift the cable management arm if it interferes with power supply removal. For information about the cable management arm, see the system's *Rack Installation Guide*.
- 1 If your system has a single power supply, turn off the system and all attached peripherals. For a redundant system, you can leave the system running and proceed to the next step.
 - 2 Disconnect the power cable from the power source.
 - 3 Disconnect the power cable from the power supply and remove the cable from the cable retention bracket.
 - 4 Release the locking tab on the left side of the power supply by pressing in toward the right, and rotate the power-supply handle up until the power supply is released from the chassis. See Figure 3-8.
 - 5 Pull the power supply straight out to clear the chassis.

Figure 3-8. Removing and Installing a Power Supply



- 1 locking tab 2 cable retention bracket 3 power-supply handle

Replacing a Power Supply

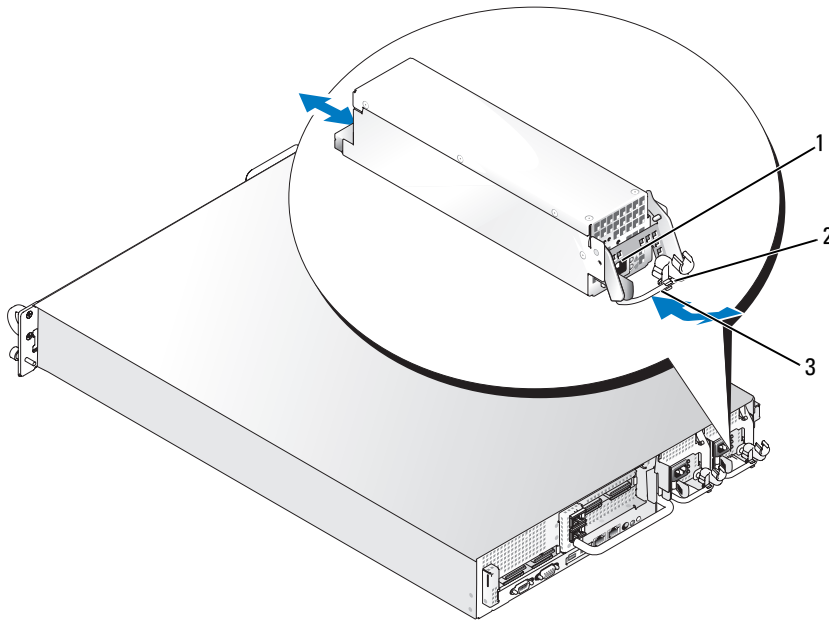
- 1 With the power-supply handle in the extended position, slide the new power supply into the chassis. See Figure 3-8.
- 2 Rotate the handle down until it is completely flush with the power-supply faceplate and the orange snap engages. See Figure 3-8.
- 3 Insert the power cable through the cable retention bracket, connect the power cable to the power supply, and plug the cable into a power outlet.

 **NOTE:** After installing a new power supply, allow several seconds for the system to recognize the power supply and determine whether it is working properly. The power supply status indicator will turn green to signify that the power supply is functioning properly. See Figure 1-4.

Removing the Power Supply Blank

Using a Phillips screwdriver, remove the screw on the left side of the blank, rotate the blank slightly to clear the bay, and remove from the chassis.

 **NOTICE:** To ensure proper system cooling, the power supply blank must be installed on the unoccupied power supply bay in a non-redundant configuration. Remove the power supply blank only if you are installing a second power supply.

Installing the Power Supply Blank

To install the power supply blank, insert the tab on the right edge of the blank into the slot in the power supply bay wall. Rotate the blank into the power supply bay and secure with the Phillips screw.

System Fans

The system includes four hot-pluggable cooling fans.

Removing a System Fan



CAUTION: Only trained service technicians are authorized to remove the system cover and access any of the components inside the system. See your *Product Information Guide* for complete information about safety precautions, working inside the computer, and protecting against electrostatic discharge.



NOTICE: The system fans are hot-pluggable. To maintain proper cooling while the system is on, replace only one fan at a time.

- 1 Open the system. See "Opening the System" on page 54.



CAUTION: Use caution when handling the fan until the fan blades stop spinning.

- 2 Raise the fan handle and pull the fan straight up from the fan cage to clear the chassis. See Figure 3-9.

Figure 3-9. Removing and Installing a Cooling Fan

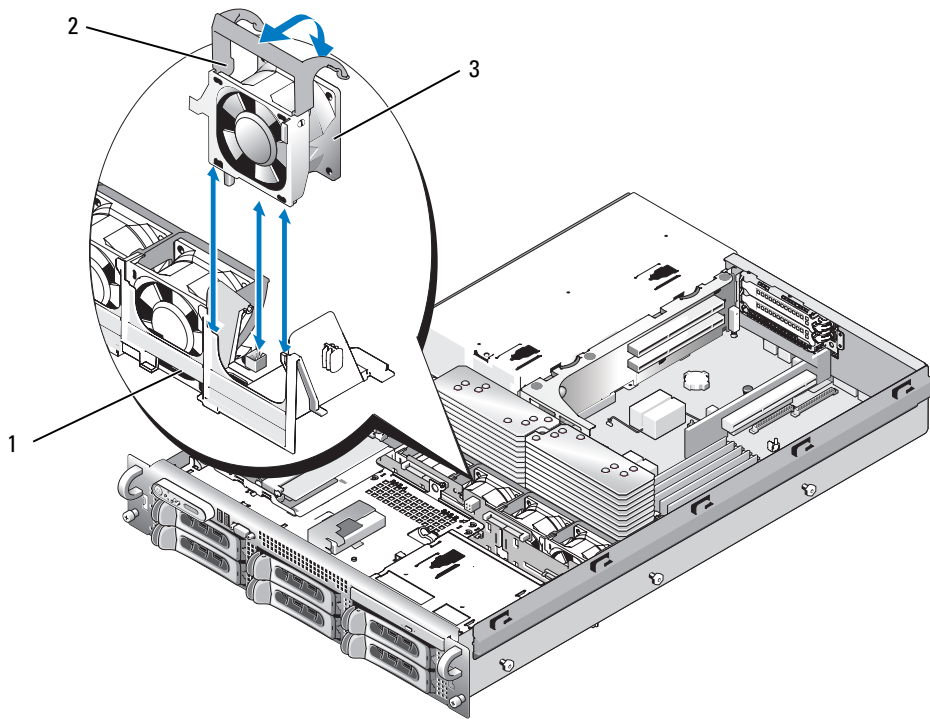

1 fan bracket

2 fan handle

3 fan

Replacing a Cooling Fan

- 1 Ensure that the fan handle is upright and lower the fan into its fan cage until the fan is fully seated. Then lower the fan handle until it snaps into place. See Figure 3-9.
- 2 Close the system. See "Closing the System" on page 55.

Cooling Shroud

The cooling shroud produces and directs airflow over the system memory modules.

⚠ CAUTION: The DIMMs are hot to the touch for some time after the system has been powered down. Allow the DIMMs to cool before handling them.

🔄 NOTICE: Never operate your system with the memory cooling shroud removed. Overheating of the system can develop quickly resulting in a shutdown of the system and the loss of data.

Removing the Cooling Shroud

- 1 The cooling shroud is secured with a latch at the end of the shroud. Release the latch by pulling it towards the outside wall of the chassis. See Figure 3-10.
- 2 Rotate the shroud upward and toward the front of the system on its hinges, and then lift the shroud out of the system.

Figure 3-10. Removing and Installing the Cooling Shroud

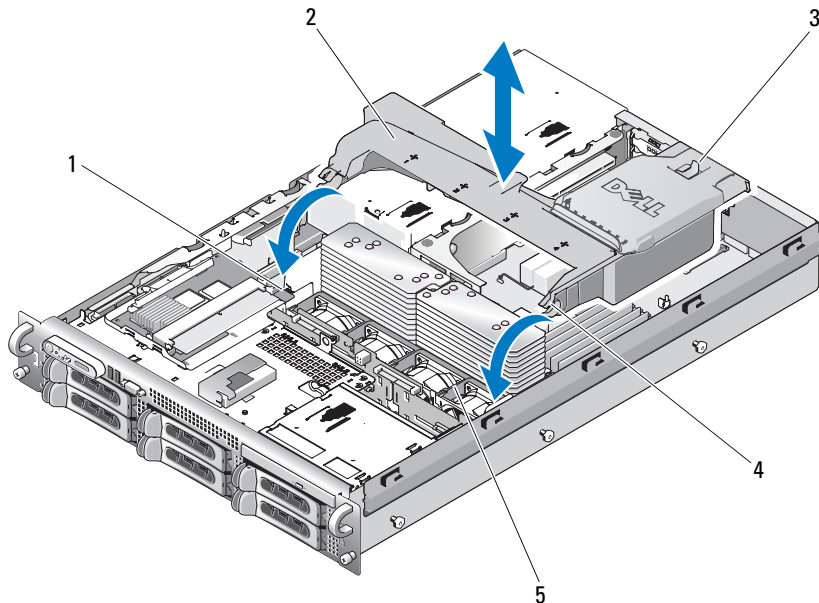

- | | | | | | |
|---|-------------------|---|----------------|---|---------------|
| 1 | shroud pivots (2) | 2 | cooling shroud | 3 | release latch |
| 4 | shroud hinges (2) | 5 | fan bracket | | |

Installing the Cooling Shroud

- 1 Align the hinges on the shroud pivots located on either end of the fan bracket. See Figure 3-10.
- 2 Slowly lower the shroud straight down into the system until the fan connector engages and the latches snap into place.

Fan Brackets

Removing the Fan Bracket



CAUTION: Only trained service technicians are authorized to remove the system cover and access any of the components inside the system. See your *Product Information Guide* for complete information about safety precautions, working inside the computer, and protecting against electrostatic discharge.

- 1 Turn off the system, including any attached peripherals, and disconnect the system from the electrical outlet.
- 2 Open the system. See "Opening the System" on page 54.
- 3 Remove the cooling shroud. See "Removing the Cooling Shroud" on page 67.
- 4 Remove the SAS controller daughter card. See "Removing a SAS Controller Daughter Card" on page 74
- 5 Remove the fans from the fan bracket. See "Removing a System Fan" on page 65.
- 6 Remove the fan bracket from the system:
 - a Press down on the release latch on the left side of the fan bracket. See Figure 3-11.
If the bracket does not disengage completely, push down slightly on the bracket when releasing the latch.
 - b Rotate the left side of the bracket upward, releasing the plastic clip from its slot in the power supply cage.
 - c Draw the bracket out of the system.

Figure 3-11. Removing and Installing the Fan Bracket

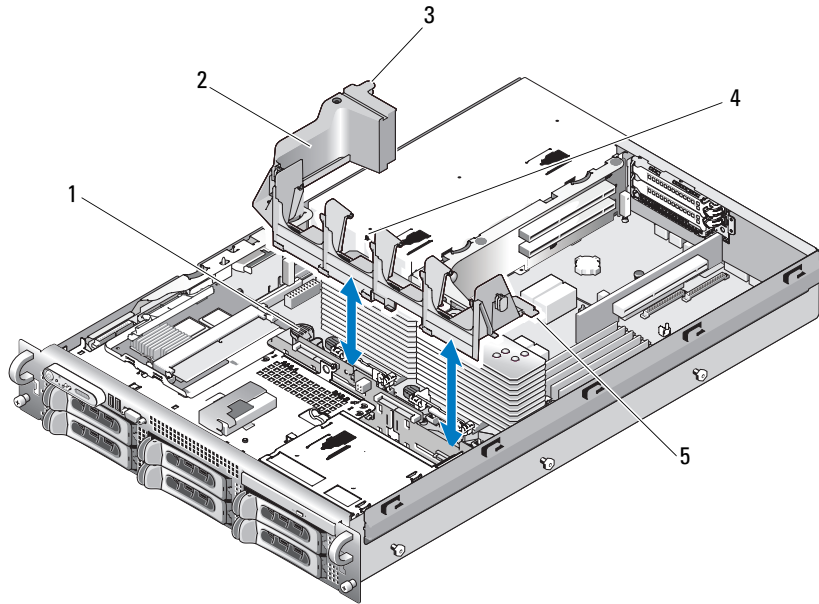

- | | | | | | |
|---|---------------------------------------|---|-------------|---|--------------|
| 1 | release latch | 2 | fan bracket | 3 | plastic clip |
| 4 | fan bracket slot in power supply cage | 5 | tabs (2) | | |

Replacing the Fan Bracket

- 1 Insert the two tabs on the right side of the fan bracket into the two slots on the system board tray.
- 2 Gently rotate the left end of the fan bracket downward into the system until the release latch and plastic clip fully engage.
- 3 Reinstall the SAS controller daughter card. See "Installing a SAS Controller Daughter Card" on page 70.
- 4 Replace the fans in the fan bracket. See "Replacing a Cooling Fan" on page 66.
- 5 Close the system. See "Closing the System" on page 55.
- 6 Reconnect the system to the electrical outlet and turn on the system and attached peripherals.

SAS Controller Daughter Card

Your system includes a dedicated slot on the sideplane for a SAS controller daughter card. The SAS controller daughter card provides the SAS storage subsystem for your system's internal hard drives. The optional SAS RAID controller daughter card allows you to set up any internal hard drives in a RAID

configuration. Although the cabling for the two types of daughter cards is different (the SAS controller daughter card has only one connector, while the SAS RAID controller daughter card has two), both cards install into the sideplane as described below. The SAS RAID controller daughter card is shown in Figure 3-12.

Installing a SAS Controller Daughter Card



NOTICE: Do not press on the RAID card DIMM while installing the RAID card into the sideplane board.



NOTE: If you are installing a replacement RAID card, do not remove the plastic cover protecting the card until after installation of the card is complete.

- 1 Turn off the system, including any attached peripherals, and disconnect the system from the electrical outlet.
- 2 Open the system. See "Opening the System" on page 54.
- 3 Disconnect the control panel cable from the sideplane board. See "Removing the Control Panel Assembly" on page 105.
- 4 Hold the SAS daughter card by its edges with the card connector facing the sideplane board.
- 5 Aligning the chassis slots on the SAS daughter card tray with the corresponding hooks on the chassis, insert the card connector into the SAS daughter card connector on the sideplane board. See Figure 3-12.

Ensure that the card is aligned with the mid-section standoff on the SAS controller daughter card and fully seat the card in the sideplane board.

Figure 3-12. Installing a SAS Controller Daughter Card

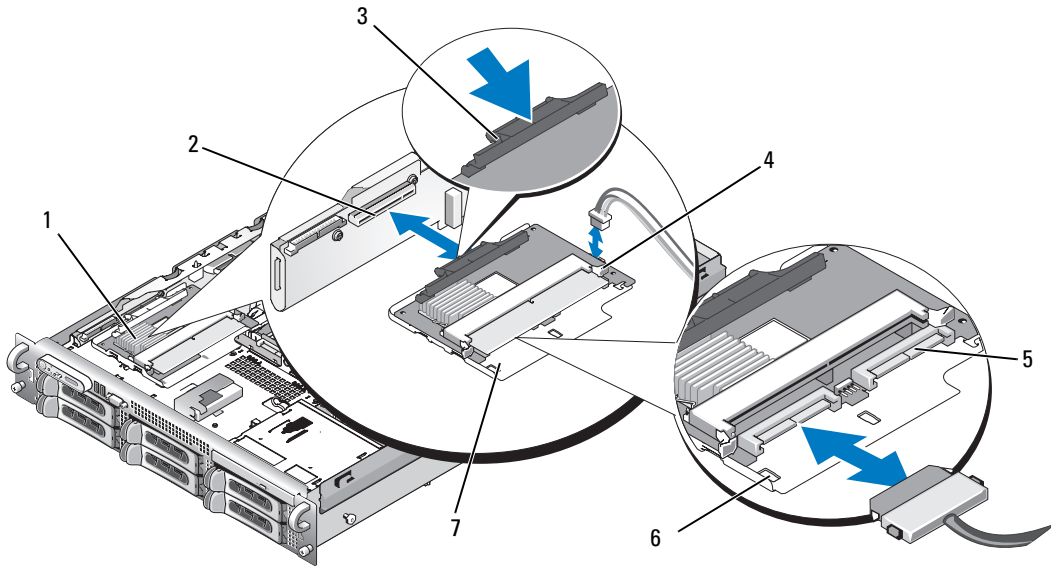

- | | | | | | |
|---|--|---|--|---|-------------------|
| 1 | SAS controller daughter card | 2 | SAS controller daughter card slot | 3 | release tab |
| 4 | SAS controller daughter card battery connector | 5 | SAS connectors 0 and 1 (for RAID card only) out to backplane SAS_A or SAS_B (for RAID card only) connector | 6 | chassis slots (2) |
| 7 | SAS controller daughter card tray | | | | |

6 Attach any cables from the SAS controller daughter card to the backplane, referring to Figure 3-13, Figure 3-14, Figure 3-15, or Figure 3-16 for the cabling guidelines for your system's card and backplane configuration.

SAS and SAS RAID Controller Daughter Card Cabling Guidelines

Figure 3-13. SAS Controller Daughter Card Cabling With all Backplanes

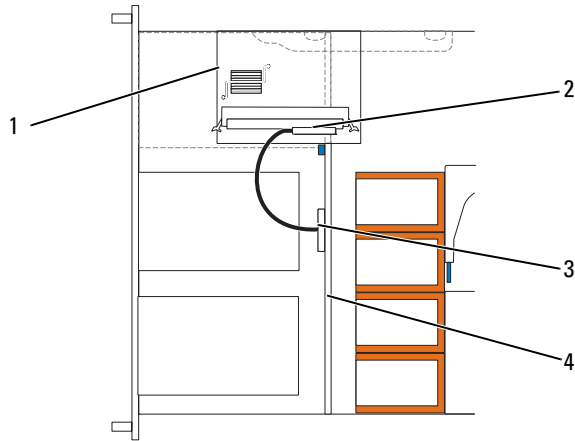

- | | | | | | |
|---|------------------------------|---|------------------|---|-----------------|
| 1 | SAS controller daughter card | 2 | SAS controller 0 | 3 | SAS backplane A |
| 4 | backplane | | | | |

Figure 3-14. SAS RAID Controller Daughter Card Cabling With 3.5-inch x6 Backplane

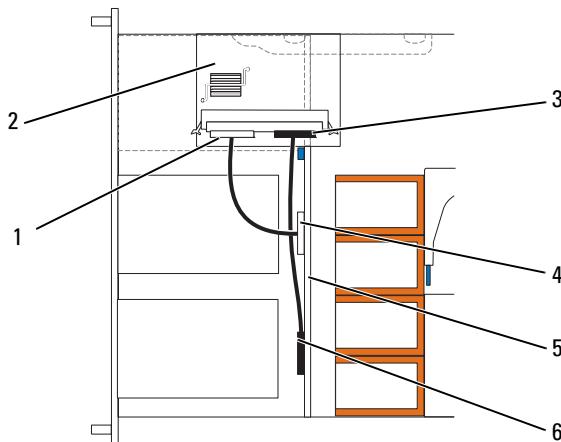

- | | | | | | |
|---|------------------|---|-----------------------------------|---|------------------|
| 1 | SAS controller 0 | 2 | SAS RAID controller daughter card | 3 | SAS controller 1 |
| 4 | SAS backplane A | 5 | 3.5-inch x6 backplane | 6 | SAS backplane B |

Figure 3-15. SAS RAID Controller Daughter Card Cabling With 3.5-inch x4 Backplane

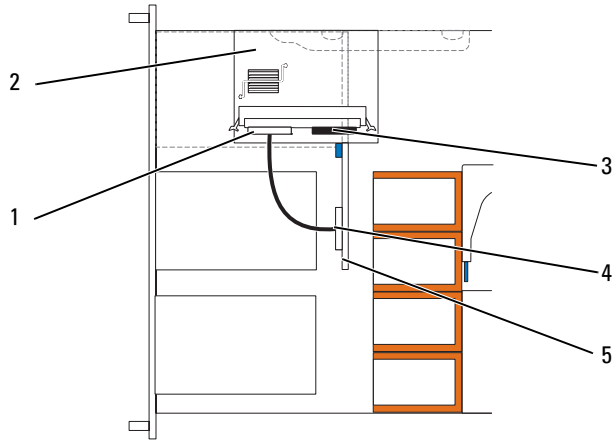

- | | | |
|--------------------|-------------------------------------|--------------------|
| 1 SAS controller 0 | 2 SAS RAID controller daughter card | 3 SAS controller 1 |
| 4 SAS backplane A | 5 3.5-inch x4 backplane | |

Figure 3-16. SAS RAID Controller Daughter Card Cabling With 2.5-inch x8 Backplane

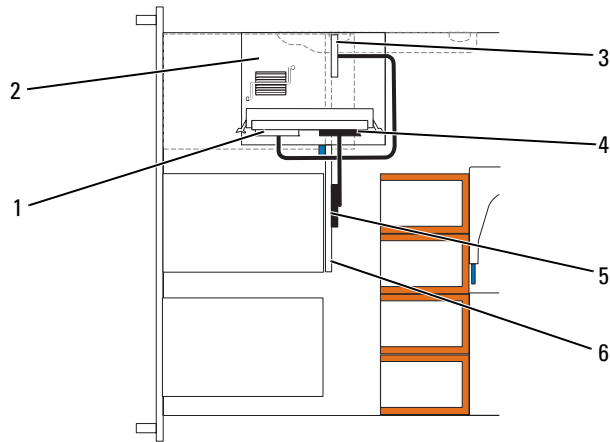

- | | | |
|--------------------|-------------------------------------|-------------------------|
| 1 SAS controller 0 | 2 SAS RAID controller daughter card | 3 SAS backplane A |
| 4 SAS controller 1 | 5 SAS backplane B | 6 2.5-inch x8 backplane |

Removing a SAS Controller Daughter Card

- 1 Disconnect any battery connectors if applicable.
- 2 Disconnect the control panel cable. See "Removing the Control Panel Assembly" on page 105
- 3 Disconnect any SAS cables from the card.
- 4 Gently press down on the release tab while sliding the SAS controller daughter card in its tray away from the sideplane connector, freeing the chassis slots on the tray from the chassis hooks, and lifting the card from the system. See Figure 3-12.

RAID Battery

Installing a RAID Battery

- 1 Insert the RAID battery into the battery carrier. See Figure 3-17.
- 2 Locate the battery bay to the right of the SAS daughter card on top of the hard drive bays.
- 3 Insert the battery carrier and RAID battery into the chassis battery carrier slots and connect the battery cable to the storage daughter card, ensuring that the battery carrier is aligned and fully seated in the slots.

Figure 3-17. Installing a RAID Battery

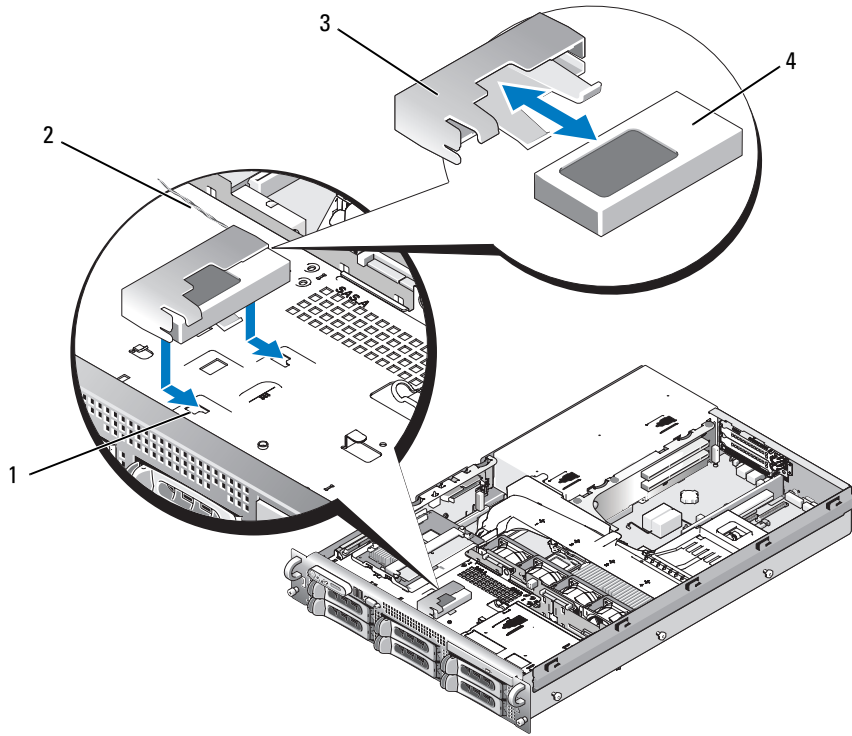

- 1 chassis battery carrier slot (2) 2 battery cable 3 battery carrier
4 SAS RAID controller daughter card battery

Removing a RAID Battery

- 1 Disconnect the cable between the RAID battery and the SAS RAID controller daughter card. See Figure 3-17.
- 2 Press down and to the left on the battery carrier to disengage the carrier from the chassis battery carrier slots.
- 3 Gently pulling back the two guides holding the RAID battery into the battery carrier, draw out the RAID battery from the battery carrier.

Configuring the Boot Device

 **NOTE:** System boot is not supported from an external device attached to a SAS or SCSI adapter. See support.dell.com for the latest support information about booting from external devices.

If you plan to boot the system from a hard drive, the drive must be attached to the primary (or boot) controller. The device that the system boots from is determined by the boot order specified in the System Setup program.





The System Setup program provides options that the system uses to scan for installed boot devices. See "Using the System Setup Program" on page 37 for information about the System Setup program.

Expansion Cards

The system is available with either a PCI-X or a PCI Express (PCIe) left riser board option. The PCI-X left riser board provides two PCI-X 64-bit/133-MHz expansion slots, while the PCIe left riser board provides one PCIe x8-lane expansion slot and one PCIe x4-lane expansion slot. The half-height center riser board provided with both PCI-X and PCIe left riser board options features one PCIe x8-lane expansion slot. The three expansion card slots are on separate buses.

Expansion Card Installation Guidelines

To identify expansion slots, see "Expansion-Card Riser-Board Components and PCI Buses" on page 142.

-  **NOTE:** The expansion-card slots are not hot-pluggable.
-  **NOTE:** Although the PCIe x4-lane expansion slot on the PCIe left riser option is physically a PCIe x8 connector, it functions only as a PCIe x4-lane slot.
-  **NOTE:** Slot 1 on the central riser supports half-length expansion cards only. Slots 2 and 3 on the left riser support full-length expansion cards.
-  **NOTE:** Your system supports up to two RAID expansion cards to manage external storage.

Installing an Expansion Card

 **CAUTION:** Only trained service technicians are authorized to remove the system cover and access any of the components inside the system. See your *Product Information Guide* for complete information about safety precautions, working inside the computer, and protecting against electrostatic discharge.

 **NOTE:** The procedure for installing expansion cards into the left and central risers is the same except that there is no card guide for cards installing into the central riser, and only half-height cards are supported on the central riser. Full-length expansion card installation is illustrated in Figure 3-18.

- 1 Unpack the expansion card and prepare it for installation.
For instructions, see the documentation accompanying the card.
- 2 Turn off the system, including any attached peripherals, and disconnect the system from the electrical outlet.
- 3 Open the system. See "Opening the System" on page 54.

- 4 Open the expansion-card guide latch and remove the filler bracket. See Figure 3-18.
- 5 Install the expansion card:
 - a If the expansion card is full length, align its front edge with the front card guide. See Figure 3-18.
 - b Position the expansion card so that the card-edge connector aligns with the expansion-card connector on the expansion-card riser board.
 - c Insert the card-edge connector firmly into the PCI card connector until the card is fully seated.
 - d When the card is seated in the connector, close the expansion-card latch. See Figure 3-18.

Figure 3-18. Installing an Expansion Card

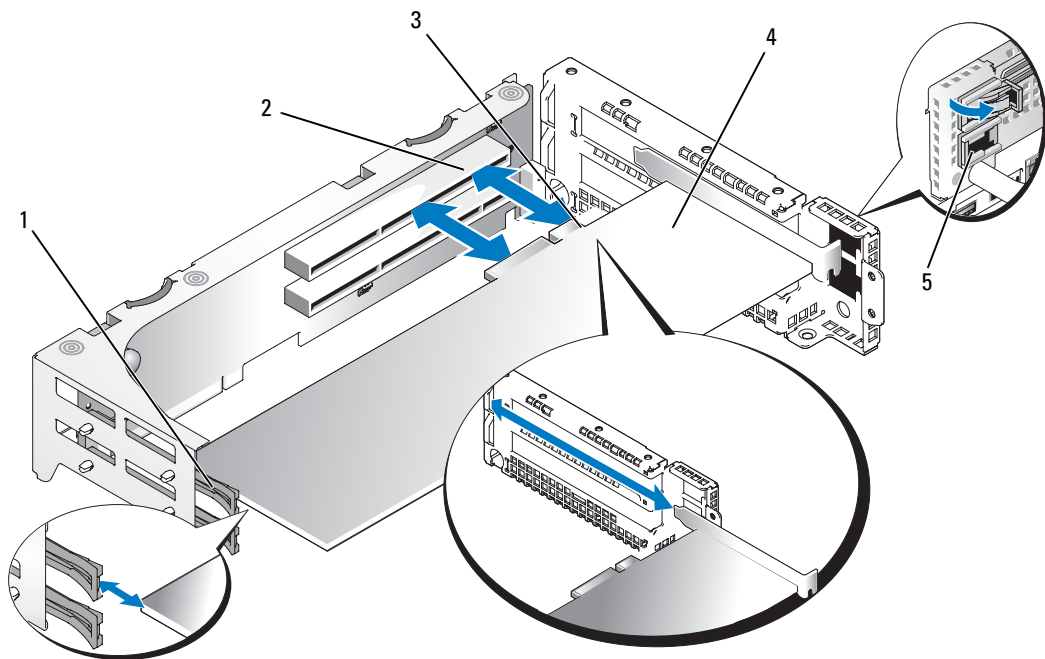

- | | | |
|--------------------|------------------------------|-----------------------|
| 1 front card guide | 2 expansion-card connector | 3 card-edge connector |
| 4 expansion card | 5 expansion-card guide latch | |

- 6 Connect any expansion-card cables for the new card.
See the documentation that came with the card for information about its cable connections.
- 7 Close the system. See "Closing the System" on page 55.

Removing an Expansion Card

 **CAUTION:** Only trained service technicians are authorized to remove the system cover and access any of the components inside the system. See your *Product Information Guide* for complete information about safety precautions, working inside the computer, and protecting against electrostatic discharge.

- 1 Turn off the system, including any attached peripherals, and disconnect the system from the electrical outlet.
- 2 Open the system. See "Opening the System" on page 54.
- 3 Disconnect all expansion-card cables.
- 4 Release the expansion card:
 - a Open the expansion-card latch. See Figure 3-18.
 - b Grasp the expansion card by its top corners, and carefully remove it from the expansion-card connector.
- 5 If you are removing the card permanently, install a metal filler bracket over the empty expansion slot opening and close the expansion-card latch.

 **NOTE:** You must install a filler bracket over an empty expansion slot to maintain Federal Communications Commission (FCC) certification of the system. The brackets also keep dust and dirt out of the system and aid in proper cooling and airflow inside the system.
- 6 Reconnect all expansion-card cables.
- 7 Close the system. See "Closing the System" on page 55.

Expansion-Card Cage

Removing the Expansion-Card Cage

 **CAUTION:** Only trained service technicians are authorized to remove the system cover and access any of the components inside the system. See your *Product Information Guide* for complete information about safety precautions, working inside the computer, and protecting against electrostatic discharge.

 **NOTE:** You must remove all expansion cards from the expansion-card cage before removing the expansion-card cage from the system.

- 1 Turn off the system, including any attached peripherals, and disconnect the system from the electrical outlet.
- 2 Open the system. See "Opening the System" on page 54.
- 3 Disconnect all expansion-card cables.
- 4 Remove any expansion cards from the expansion-card cage. See "Removing an Expansion Card" on page 78.
- 5 Press the two blue release latches on the expansion-card cage. See Figure 3-19.

Figure 3-19. Installing and Removing the Expansion-Card Cage

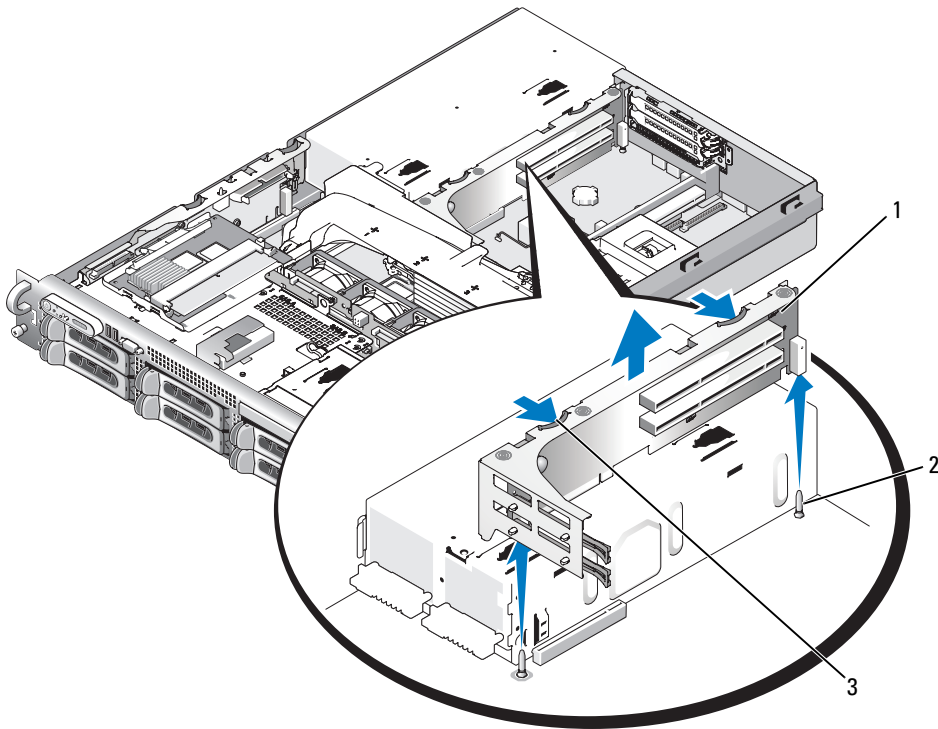

1 expansion-card cage

2 chassis pins (2)

3 release latches (2)

6 Lift the cage straight up to clear the chassis. See Figure 3-19.

Replacing the Expansion-Card Cage

⚠ CAUTION: Only trained service technicians are authorized to remove the system cover and access any of the components inside the system. See your *Product Information Guide* for complete information about safety precautions, working inside the computer, and protecting against electrostatic discharge.

- 1 Align the guides on each end of the expansion-card cage with the pins on the system board, and lower the cage. See Figure 3-19.
- 2 Install any expansion cards.
- 3 Reconnect all expansion-card cables.
- 4 Close the system. See "Closing the System" on page 55.

Installing a RAC Card

⚠ CAUTION: Only trained service technicians are authorized to remove the system cover and access any of the components inside the system. See your *Product Information Guide* for complete information about safety precautions, working inside the computer, and protecting against electrostatic discharge.

The optional Remote Access Controller (RAC) provides a set of advanced features for managing the server remotely. The following procedure describes the steps for installing the optional RAC card.

- 1 Turn off the system, including any attached peripherals, and disconnect the system from the electrical outlet.
- 2 Open the system. See "Opening the System" on page 54.
- 3 Remove the plastic filler plug from the system back panel. See Figure 3-20.
- 4 Remove the central riser board. See "Removing the Central Riser Board" on page 100.
- 5 Angle the RAC card so that its NIC connector inserts through the back-panel RAC card opening, and then straighten the card.

Figure 3-20. Installing a RAC Card

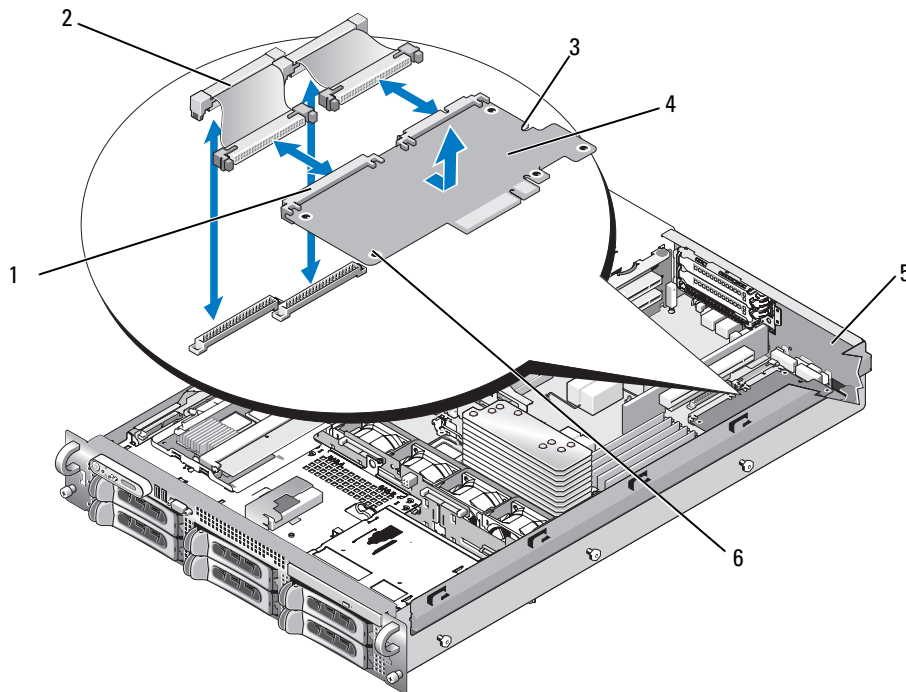

- | | | | | | |
|---|-------------------------|---|---------------------|---|----------------------------|
| 1 | RAC-card connectors (2) | 2 | RAC-card cables (2) | 3 | retention standoff hole |
| 4 | RAC card | 5 | filler plug | 6 | support standoffs holes(2) |

- 6 Align the front edge of the RAC card with the two front plastic retention standoffs adjacent to the RAC system board connector, and press down the side of the card until it is fully seated. See Figure 3-20.

When the front of the card is fully seated, the plastic standoff snaps over the edge of the card.

- 7 Connect the two short ribbon cables to the RAC card and the system board. See Figure 6-2 for the connector locations



NOTICE: Be careful when attaching cables to the system board that you do not damage the surrounding system board components.

- a Connect one cable to connector 1 on the RAC card and to RAC_CONN1 on the system board.
- b Connect the second cable to connector 2 on the RAC card and to RAC_CONN2 on the system board. Reinstall the central riser board. See "Installing the Central Riser Board" on page 100.



NOTICE: When detaching the RAC cables from the system board, squeeze the metal ends of the cable connectors and gently work the connector out of the socket. Do not pull on the cable to unseat the connector. Doing so can damage the cable.

- 8 Close the system. See "Closing the System" on page 55.
- 9 Reconnect the system and peripherals to their power sources, and turn them on.

See the RAC card documentation for information on configuring and using the RAC card.

Optical Drive

An optional slimline optical drive is mounted on a tray that slides in the front panel and connects to the controllers on the system board through the SAS backplane board.

Removing the Optical Drive



CAUTION: Only trained service technicians are authorized to remove the system cover and access any of the components inside the system. See your *Product Information Guide* for complete information about safety precautions, working inside the computer, and protecting against electrostatic discharge.

- 1 Turn off the system, including any attached peripherals, and disconnect the system from its electrical outlet.
- 2 Remove the bezel. See "Removing the Front Bezel" on page 53.
- 3 Open the system. See "Opening the System" on page 54
- 4 Disconnect the optical drive cable from the back of the drive.
- 5 To remove the optical drive, press down and forward on the blue tray release tab and slide the drive tray out of the system. See Figure 3-21.

Figure 3-21. Removing and Installing the Optical Drive Tray

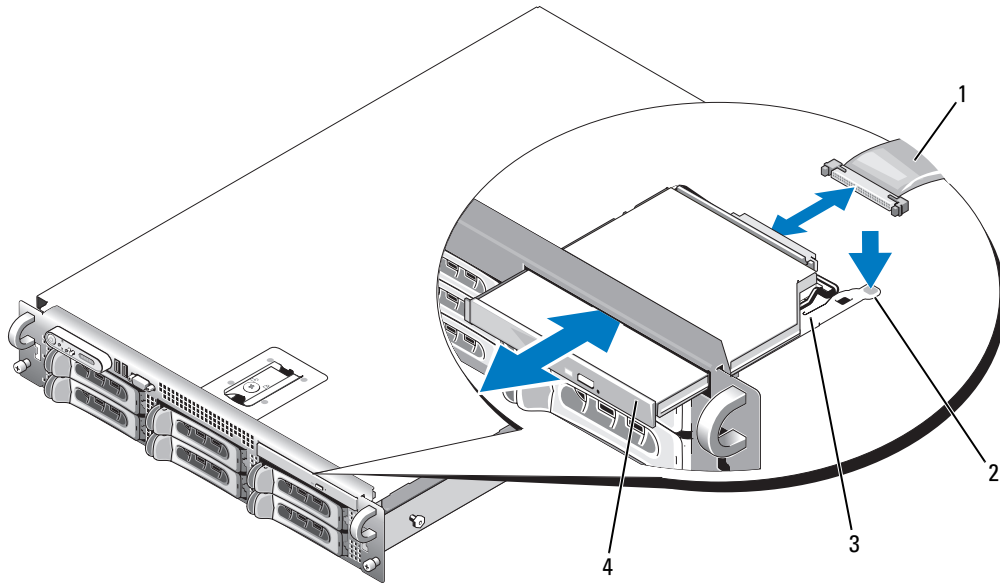

- 1 optical-drive cable 2 optical-drive release tab 3 optical -drive tray
4 optical drive

Installing the Optical Drive

- 1** Align the optical drive tray with its opening in the front panel.
The optical drive opening is above the hard-drive slots on the far right, or the flex bay, depending on your system's drive configuration (the hard-drives slots are identified by labels on the front panel of the system).
- 2** Slide in the drive tray until the tray snaps into place. See Figure 3-21.
- 3** Connect the optical drive cable to the connector on the back of the drive.
- 4** Close the system. See "Closing the System" on page 55.
- 5** Replace the bezel. See "Replacing the Front Bezel" on page 54.
- 6** Reconnect your system and peripherals to their electrical outlets, and turn on the system.

Diskette Drive

Removing the Diskette Drive From the System



CAUTION: Only trained service technicians are authorized to remove the system cover and access any of the components inside the system. See your *Product Information Guide* for complete information about safety precautions, working inside the computer, and protecting against electrostatic discharge.

- 1 Turn off the system, including any attached peripherals, and disconnect the system from the electrical outlet.
- 2 Remove the front bezel, if attached. See "Removing the Front Bezel" on page 53.
- 3 Open the system. See "Opening the System" on page 54.
- 4 If your system configuration includes a tape backup device installed in the optional media bay, remove the tape backup device's strain relief bracket. See "Removing and Replacing the Tape Drive Cable Retention Bracket" on page 88.
- 5 Disconnect the cable from the back of the diskette drive.
- 6 Release the diskette drive carrier from its slot in the media bay:
 - a Gently squeeze down on the plastic tabs on the side of the carrier while pushing toward the front of the system until you feel the carrier sliding freely forward.
 - b Slide the carrier forward and out of the chassis. See Figure 3-23.

Figure 3-22. Installing and Removing the Diskette Drive From the System

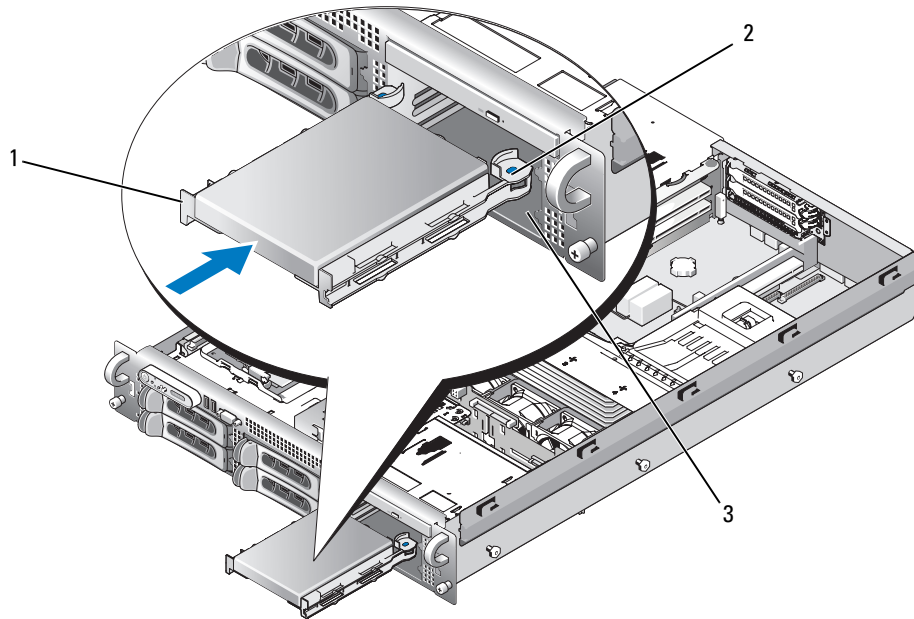

- 1 diskette drive carrier 2 release tabs (2) 3 media bay

Installing the Diskette Drive Into the System

⚠ CAUTION: Only trained service technicians are authorized to remove the system cover and access any of the components inside the system. See your *Product Information Guide* for complete information about safety precautions, working inside the computer, and protecting against electrostatic discharge.

- 1 Turn off the system, including any attached peripherals, and disconnect the system from the electrical outlet.
- 2 Remove the front bezel, if attached. See "Removing the Front Bezel" on page 53.
- 3 Open the system. See "Opening the System" on page 54.
- 4 Install the diskette drive carrier into the system:
 - a Align the slots on the bottom of the diskette drive carrier with the drive bay rails in the media bay.
 - b Push the carrier toward the system front plate until the plastic latch on the carrier locks into position.
- 5 Attach one end of the ribbon cable to the floppy connector (FLOPPY) on the system board and the other end to the connector on the rear of the diskette drive. See Figure 6-2 for the location of the floppy cable connector on the system board.
- 6 Close the system. See "Closing the System" on page 55.

- 7 Replace the front bezel if removed in step 2. See "Replacing the Front Bezel" on page 54.
- 8 Reconnect the system and peripherals to their electrical outlets.

Removing the Diskette Drive From the Drive Carrier

- 1 Remove the diskette drive from the system. See "Removing the Diskette Drive From the System" on page 83.
- 2 Gently draw one side of the carrier away from the diskette drive until the drive pops from the tray. See Figure 3-23.

Figure 3-23. Installing and Removing the Diskette Drive Into and From the Drive Carrier

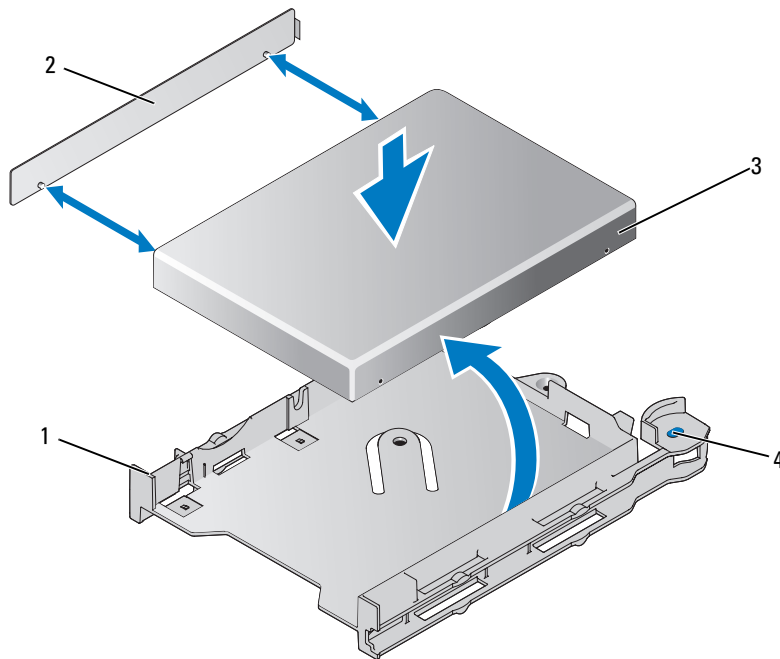

- 1 diskette drive tray 2 shim 3 diskette drive
4 diskette drive release tabs (2)

Installing the Diskette Drive Into the Drive Carrier

- 1 Align the back of the diskette drive with the back of the carrier.
- 2 Add the shim to the drive.
- 3 Gently push the drive into the carrier until it pops in securely. See Figure 3-23.

SCSI Tape Drive

This section describes how to configure and install an internal SCSI tape drive.

NOTE: Installing a SCSI tape drive requires an optional SCSI controller card.

Removing and Installing an Internal SCSI Tape Drive

NOTICE: See "Protecting Against Electrostatic Discharge" in the safety instructions in your *Product Information Guide*.

- 1 Turn off the system, including any attached peripherals, and disconnect the system from the electrical outlet.
- 2 Remove the tape drive carrier from the media bay by squeezing the release tabs on either side of the carrier down and forward, sliding the carrier gently from the bay. See Figure 3-24.

Figure 3-24. Removing and Installing the Tape Drive Carrier

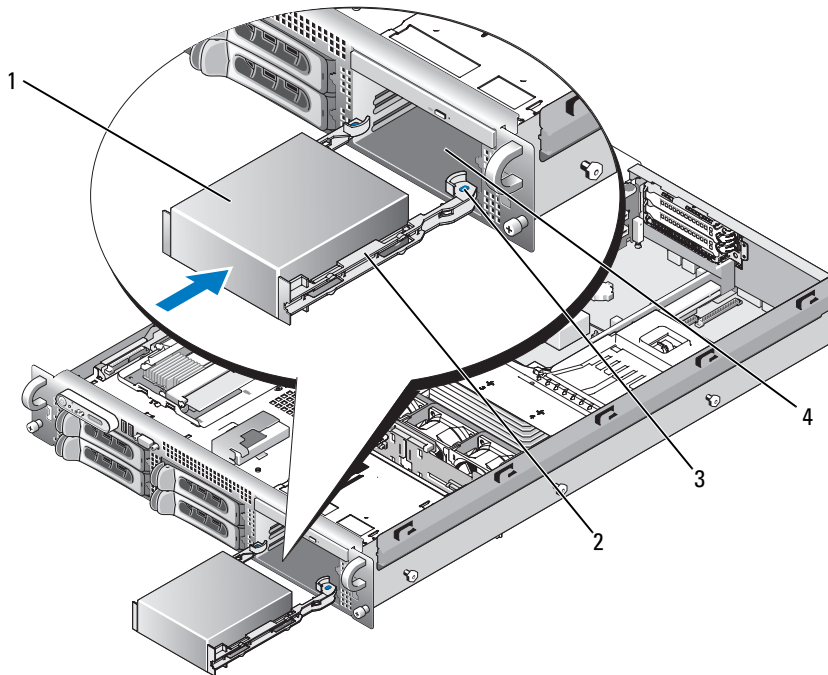

- | | | | | | |
|---|------------------|---|------------------|---|-----------------|
| 1 | tape drive blank | 2 | tape drive rails | 3 | release tab (2) |
| 4 | media bay | | | | |

- 3 Remove the four screws affixing the tape drive blank to the rails, and set the rails aside for installation onto the drive. See Figure 3-25.

- 4 Prepare the tape drive for installation.
Ground yourself by touching an unpainted metal surface on the back of the system, unpack the drive (and controller card, if applicable), and compare the jumper and switch settings with those in the drive documentation.
- 5 Aligning the four holes on the tape drive with the four screw holes on the tape drive rails, affix the rails to the drive.
- 6 Insert the tape drive along the rails in the media bay. See Figure 3-25.

Figure 3-25. Removing and Installing an Internal SCSI Tape Drive

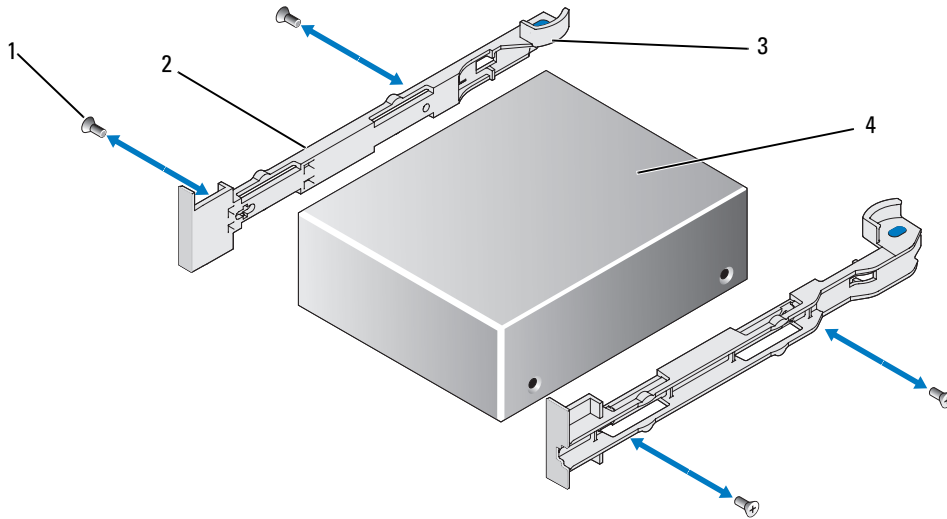

- | | | | | | |
|---|------------|---|----------------------|---|-----------------------|
| 1 | screws (4) | 2 | tape drive rails (2) | 3 | rail release tabs (2) |
| 4 | tape drive | | | | |

- 7 Route the tape drive's SCSI interface cable through the tape drive cable retention bracket and connect it to the connector on the SCSI controller card. See "Removing and Replacing the Tape Drive Cable Retention Bracket" on page 88.
- 8 Connect the tape drive power cable to the tape drive power connector on the backplane. See Figure 6-4 or Figure 6-5 for the connector location.
- 9 Reconnect the system to its electrical outlet and turn the system on, including any attached peripherals.
- 10 Perform a tape backup and verification test with the drive as instructed in the software documentation that came with the drive.

Removing and Replacing the Tape Drive Cable Retention Bracket

The optional tape drive available with the 3.5" x4 and 2.5" x8 backplane configurations connects to the system board through an expansion card plugged into one of the PCI expansion card slots. The tape drive cable is routed along the right side of the chassis and behind the tape drive cable retention bracket.

To remove the tape drive cable retention bracket, gently draw the blue release latch toward the center of the system while sliding the cable retention bracket toward the front of the system and disengaging the bracket from the chassis wall. See Figure 3-26.

To replace the bracket, align the bracket clips with their slots on the chassis wall, then slide the bracket toward the back of the system until all the clips and the blue release latch are fully engaged.

Figure 3-26. Installing and Removing the Tape Drive Cable Retention Bracket

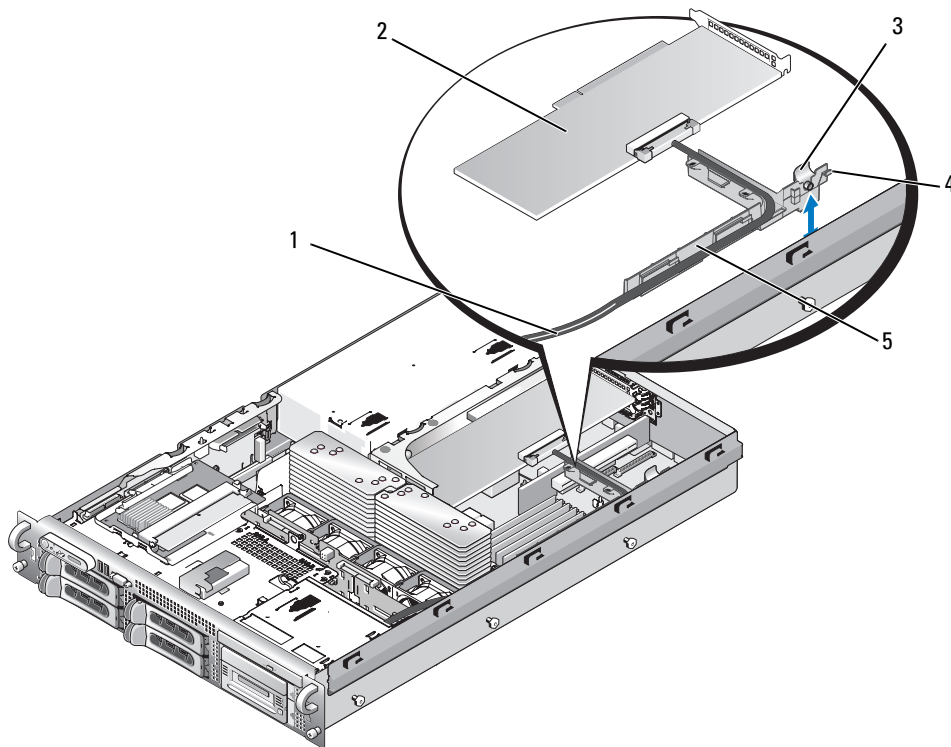

1 tape drive cable

2 SCSI controller card

3 release latch

4 bracket clips (6)

5 tape drive cable retention bracket

System Memory

You can upgrade your system memory to a maximum of 32 GB by installing 533MHz or 667MHz fully buffered (FB) DDR II memory modules in sets of 256-MB, 512-MB, 1-GB, 2-GB, or 4-GB. The eight memory sockets are located on the system board under the cooling shroud adjacent to the power supply bays. See Figure 6-2. You can purchase memory upgrade kits from Dell.

 **NOTICE:** If you remove your original memory modules from the system during a memory upgrade, keep them separate from any new memory modules that you may have, even if you purchased the new memory modules from Dell. Use only 533 MHz or 667 MHz DDR II FB-DIMMs.

The memory module sockets are divided into two equal branches (0 and 1). Each branch consists of two channels:

- Channel 0 and channel 1 are in branch 0.
- Channel 2 and channel 3 are in branch 1.

Each channel consists of two DIMM sockets:

- Channel 0 contains DIMM_1, DIMM_5.
- Channel 1 contains DIMM_2, DIMM_6.
- Channel 2 contains DIMM_3, DIMM_7.
- Channel 3 contains DIMM_4, DIMM_8.

The first DIMM socket of each channel has white release tabs.

General Memory Module Installation Guidelines

To ensure optimal performance of your system, observe the following guidelines when configuring your system memory.

- Use only qualified Fully-Buffered DIMMs (FBDs). FBDs can be either single-ranked or dual-ranked. FBDs marked with a 1R are single-ranked and modules marked with a 2R are dual-ranked.
- A minimum of two identical FBDs must be installed.
- DIMM sockets must be populated by lowest number first.
- FBDs must be installed in pairs of matched memory size, speed, and technology, and the total number of FBDs in the configuration must total two, four, or eight. For best system performance, all four, or eight FBDs should be identical memory size, speed, and technology.
- Memory sparing and memory mirroring require eight FBDs, and all FBDs must be of identical memory size, speed, and technology.
- Memory sparing and memory mirroring cannot be implemented at the same time.

Non-Optimal Memory Configurations

System performance can be affected if your memory configuration does not conform to the preceding installation guidelines. Your system may issue an error message during startup stating that your memory configuration is non-optimal.

Memory Sparing Support

The system supports memory sparing if eight identical memory modules are installed in the system. The memory sparing feature must be enabled in the System Setup program and can be used only if memory mirroring is not enabled.

Memory sparing allocates four ranks of DIMM memory to the spare bank. These four ranks consist of the first rank of memory in DIMM sockets 1 through 4. For single-rank DIMMs, the entire capacity of the four DIMMs is allocated to sparing whereas for dual-rank DIMMs, only half of the four-DIMM capacity is allocated to sparing. Table 3-2 shows how memory sparing splits the available and spared memory in each of the single- and dual-ranked memory module combinations.

Table 3-2. Memory Sparing Configurations

DIMMs	Size/Type	Total Memory	Available	Spare
8	256-MB single-rank	2 GB	1 GB	1 GB
	512-MB single-rank	4 GB	2 GB	2 GB
	1-GB single-rank	8 GB	4 GB	4 GB
	2-GB single-rank	16 GB	8 GB	8 GB
	2-GB dual-rank	16 GB	12 GB	4 GB
	4-GB dual-rank	32 GB	24 GB	8 GB

Memory Mirroring Support

The system supports memory mirroring if eight identical memory modules are installed in the system. Mirroring must be enabled in the System Setup program and can be used only if memory sparing is not enabled. In a mirrored configuration, the total available system memory is one-half of the total installed memory.

Installing Memory Modules



CAUTION: Only trained service technicians are authorized to remove the system cover and access any of the components inside the system. See your *Product Information Guide* for complete information about safety precautions, working inside the computer, and protecting against electrostatic discharge.

- 1 Turn off the system, including any attached peripherals, and disconnect the system from the electrical outlet.
- 2 Open the system. See "Opening the System" on page 54.
- 3 Remove the memory cooling shroud. See "Removing the Cooling Shroud" on page 67.

➡ NOTICE: Never remove the memory cooling shroud without first powering down the system. Overheating of the system can develop quickly resulting in a shutdown of the system and the loss of data.

4 Locate the memory module sockets on the system board. See Figure 6-2.

⚠ CAUTION: The DIMMs are hot to the touch for some time after the system has been powered down. Allow time for the DIMMs to cool before handling them. Handle the DIMMs by the card edges and avoid touching the DIMM components.

5 Press the ejectors on the memory module socket down and out, as shown in Figure 3-27, to allow the memory module to be inserted into the socket.

Figure 3-27. Installing and Removing a Memory Module

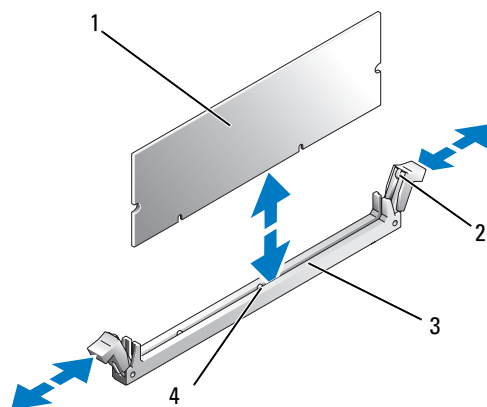

1 memory module

2 memory module socket
ejectors (2)

3 socket

4 alignment key

6 Align the memory module's edge connector with the alignment key on the memory module socket, and insert the memory module in the socket.

🔪 NOTE: The memory module socket has an alignment key that allows you to install the memory module in the socket in only one way.





7 Press down on the memory module with your thumbs while pulling up on the ejectors with your index fingers to lock the memory module into the socket.

When the memory module is properly seated in the socket, the ejectors on the memory module socket align with the ejectors on the other sockets that have memory modules installed.

8 Repeat step 3 through step 7 of this procedure to install the remaining memory modules.

- 9 Replace the memory cooling shroud. See "Installing the Cooling Shroud" on page 67.
-  **NOTICE:** Never operate your system with the memory cooling shroud removed. Overheating of the system can develop quickly resulting in a shutdown of the system and the loss of data.
- 10 Close the system. See "Opening the System" on page 54.
- 11 (Optional) Enter the System Setup program, and check the **System Memory** setting on the main **System Setup** screen. See "Entering the System Setup Program" on page 37.
The system should have already changed the value to reflect the newly installed memory.
- 12 If the value is incorrect, one or more of the memory modules may not be installed properly. Repeat step 2 through step 11 of this procedure, checking to ensure that the memory modules are firmly seated in their sockets.
- 13 Run the system memory test in the system diagnostics. See "Running the System Diagnostics" on page 132.

Removing Memory Modules

-  **CAUTION:** Only trained service technicians are authorized to remove the system cover and access any of the components inside the system. See your *Product Information Guide* for complete information about safety precautions, working inside the computer, and protecting against electrostatic discharge.
- 1 Turn off the system, including any attached peripherals, and disconnect the system from the electrical outlet.
- 2 Open the system. See "Opening the System" on page 54.
- 3 Remove the memory cooling shroud. See "Removing the Cooling Shroud" on page 67.
-  **NOTICE:** Never remove the memory cooling shroud without first powering down the system. Overheating of the system can develop quickly resulting in a shutdown of the system and the loss of data.
- 4 Locate the memory module sockets on the system board. See Figure 6-2.
-  **CAUTION:** The DIMMs are hot to the touch for some time after the system has been powered down. Allow the DIMMs to cool before handling them. Handle the DIMMs by the card edges, and avoid touching the DIMM components.
- 5 Press down and out on the ejectors on each end of the socket until the memory module pops out of the socket. See Figure 3-27.
- 6 Replace the memory cooling shroud. See "Installing the Cooling Shroud" on page 67.
-  **NOTICE:** Never operate your system with the memory cooling shroud removed. Overheating of the system can develop quickly resulting in a shutdown of the system and the loss of data.
- 7 Close the system. See "Closing the System" on page 55.

Activating the Integrated NIC TOE

To add TCP/IP Offload Engine (TOE) functionality to the system's integrated NIC, install the TOE NIC hardware key in the TOE_KEY socket on the system board (see Figure 6-2.)

Processors

You can upgrade your processor(s) to take advantage of future options in speed and functionality. Each processor and its associated internal cache memory are contained in a land grid array (LGA) package that is installed in a ZIF socket on the system board.

Removing a Processor

 **CAUTION:** Only trained service technicians are authorized to remove the system cover and access any of the components inside the system. See your *Product Information Guide* for complete information about safety precautions, working inside the computer, and protecting against electrostatic discharge.

- 1 Prior to upgrading your system, download the latest system BIOS version on support.dell.com.
- 2 Turn off the system, including any attached peripherals, and disconnect the system from the electrical outlet.
- 3 Open the system. See "Opening the System" on page 54.
- 4 Remove the fans. See "Removing a System Fan" on page 65
- 5 Remove the fan bracket. See "Removing the Fan Bracket" on page 68.

 **NOTICE:** When you remove the heat sink, the possibility exists that the processor might adhere to the heat sink and be removed from the socket. It is recommended that you remove the heat sink while the processor is still warm.

 **NOTICE:** Never remove the heat sink from a processor unless you intend to remove the processor. The heat sink is necessary to maintain proper thermal conditions.

- 6 Press the blue tab on the end of one of the heat-sink retention levers to disengage the lever, then lift the lever 90 degrees. See Figure 3-28.

Figure 3-28. Installing and Removing the Heat Sink

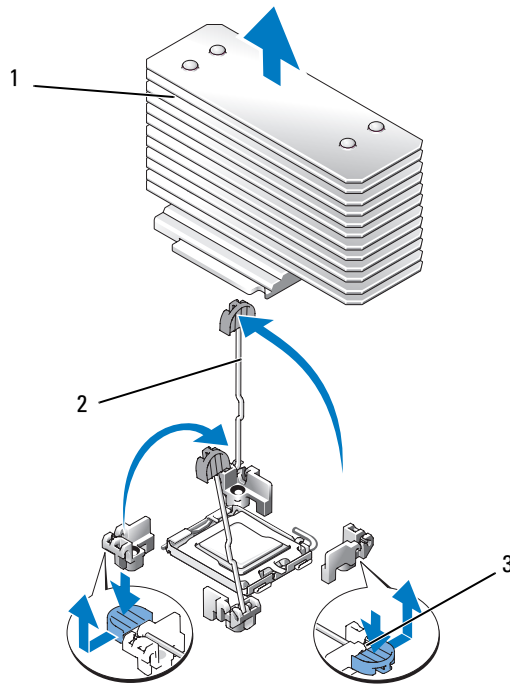

1 heat sink 2 heat-sink retention levers (2) 3 retention lever latch

- 7 Wait 30 seconds for the heat sink to loosen from the processor.
- 8 Open the other heat sink retention lever.
- 9 If the heat sink has not separated from the processor, carefully rotate the heat sink in a clockwise, then counterclockwise direction until it releases from the processor. Do not pry the heat sink from the processor.
- 10 Lift the heat sink off of the processor and set the heat sink aside.
- 11 Pull the socket-release lever 90 degrees upward until the processor is released from the socket. See Figure 3-29.
- 12 Rotate the processor shield upward and out of the way.

Figure 3-29. Installing and Removing a Processor

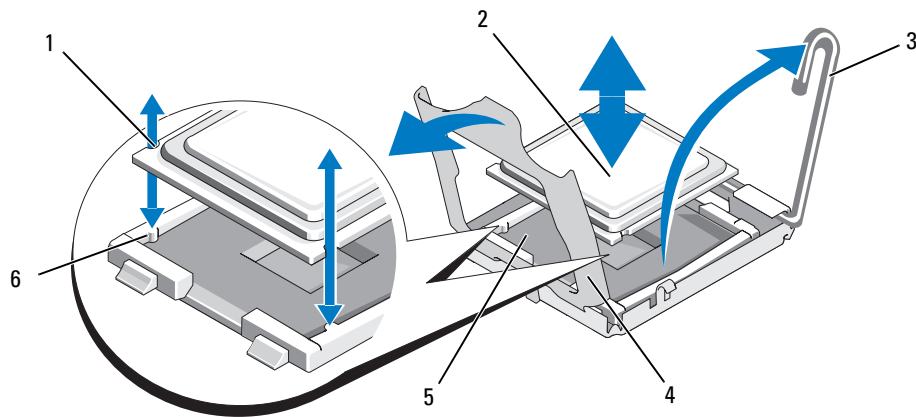

- | | | | | | |
|---|------------------------|---|------------|---|----------------------|
| 1 | notch in processor (2) | 2 | processor | 3 | socket-release lever |
| 4 | processor shield | 5 | ZIF socket | 6 | socket key (2) |

13 Lift the processor out of the socket and leave the release lever up so that the socket is ready for the new processor.

➔ NOTICE: Be careful not to bend any of the pins on the ZIF socket when removing the processor. Bending the pins can permanently damage the system board.

Installing a Processor

- 1 Unpack the new processor.
- 2 Align the processor with the socket keys on the ZIF socket. See Figure 3-29.
- 3 Install the processor in the socket.

➔ NOTICE: Positioning the processor incorrectly can permanently damage the system board or the processor when you turn it on. When placing the processor in the socket, be careful not to bend the pins in the socket.

- a If the release lever on the processor socket is not positioned all the way up, move it to that position.
- b With the processor and the socket keys aligned, set the processor lightly in the socket.

➔ NOTICE: Do not use force to seat the processor. When the processor is positioned correctly, it engages easily into the socket.

- c Close the processor shield. See Figure 3-29.
- d When the processor is fully seated in the socket, rotate the socket release lever back down until it snaps into place, securing the processor. See Figure 3-29.

- 4 Install the heat sink.



NOTE: If you did not receive a replacement heat sink, use the heat sink that you removed in step 10.

- a If you receive a heat sink and pre-applied thermal grease with your processor kit, remove the protective sheet from the thermal grease layer on top of the heat sink.

If you did not receive a replacement heat sink with your processor kit, do the following:

- Using a clean lint-free cloth, remove the existing thermal grease from the heat sink you removed in step 10.
- Open the grease packet included with your processor kit and apply thermal grease evenly to the top of the processor.

- b Place the heat sink on the processor. See Figure 3-28.

- c Close one of the two heat sink retention levers until it locks. See Figure 3-28.

- d Repeat for the other heat sink retention lever.

- 5 Reinstall the fan bracket. See "Replacing the Fan Bracket" on page 69.

- 6 Close the system. See "Closing the System" on page 55.

As the system boots, it detects the presence of the new processor and automatically changes the system configuration information in the System Setup program.

- 7 Press <F2> to enter the System Setup program, and check that the processor information matches the new system configuration. See "Entering the System Setup Program" on page 37.

- 8 Run the system diagnostics to verify that the new processor operates correctly.

See "Running the System Diagnostics" on page 132 for information about running the diagnostics.

System Battery

The system battery is a 3.0-volt (V), coin-cell battery.

Replacing the System Battery



CAUTION: Only trained service technicians are authorized to remove the system cover and access any of the components inside the system. See your *Product Information Guide* for complete information about safety precautions, working inside the computer, and protecting against electrostatic discharge.



CAUTION: There is a danger of a new battery exploding if it is incorrectly installed. Replace the battery only with the same or equivalent type recommended by the manufacturer. Discard used batteries according to the manufacturer's instructions. See your *System Information Guide* for additional information.

- 1 Turn off the system, including any attached peripherals, and disconnect the system from the electrical outlet.
- 2 Open the system. See "Opening the System" on page 54

3 Locate the battery socket. See "System Board Connectors" on page 137.

➔ **NOTICE:** If you pry the battery out of its socket with a blunt object, be careful not to touch the system board with the object. Ensure that the object is inserted between the battery and the socket before you attempt to pry out the battery. Otherwise, you may damage the system board by prying off the socket or by breaking circuit traces on the system board.

➔ **NOTICE:** To avoid damage to the battery connector, you must firmly support the connector while installing or removing a battery.

4 Remove the system battery.

- a Support the battery connector by pressing down firmly on the positive side of the connector.
- b While supporting the battery connector, press the battery toward the positive side of the connector and pry it up out of the securing tabs at the negative side of the connector.

Figure 3-30. Replacing the System Battery

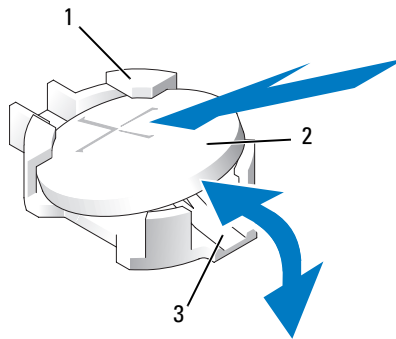

1 positive side of battery connector

2 system battery

3 negative side of battery connector

➔ **NOTICE:** To avoid damage to the battery connector, you must firmly support the connector while installing or removing a battery.

5 Install the new system battery.

- a Support the battery connector by pressing down firmly on the positive side of the connector.
- b Hold the battery with the "+" facing up, and slide it under the securing tabs at the positive side of the connector.
- c Press the battery straight down into the connector until it snaps into place.

6 Close the system. See "Closing the System" on page 55.

7 Reconnect the system to its electrical outlet and turn the system on, including any attached peripherals.

- 8 Enter the System Setup program to confirm that the battery is operating properly. See "Entering the System Setup Program" on page 37.
- 9 Enter the correct time and date in the System Setup program's **Time** and **Date** fields.
- 10 Exit the System Setup program.
- 11 To test the newly installed battery, turn off the system and disconnect it from the electrical outlet for at least an hour.
- 12 After an hour, reconnect the system to its electrical outlet and turn it on.
- 13 Enter the System Setup program and if the time and date are still incorrect, see "Getting Help" on page 147 for instructions on obtaining technical assistance.

Expansion-Card Riser Boards

Removing the Left Expansion-Card Riser Board



CAUTION: Only trained service technicians are authorized to remove the system cover and access any of the components inside the system. See your *Product Information Guide* for complete information about safety precautions, working inside the computer, and protecting against electrostatic discharge.

- 1 Turn off the system and attached peripherals, and disconnect the system from the electrical outlet.
- 2 Open the system. See "Opening the System" on page 54.
- 3 Remove any expansion cards from the left riser expansion-card slots. See "Removing an Expansion Card" on page 78.
- 4 Remove the expansion-card cage. See "Removing the Expansion-Card Cage" on page 78.
- 5 Remove the expansion-card riser board:
 - a Pull the expansion-card riser release pin. See Figure 3-31.
 - b While pulling the release pin, slide the riser board away from the expansion card openings.
 - c Lift the riser board from the six securing tabs.

Figure 3-31. Replacing the Left Riser Board

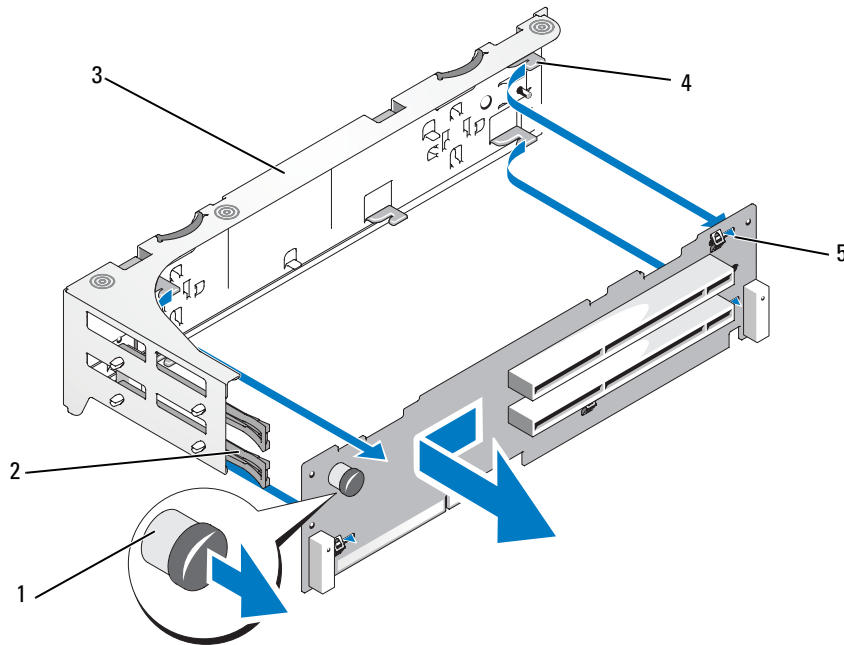

- | | | | | | |
|---|-------------------------|---|--------------------------|---|---------------------|
| 1 | riser release pin | 2 | expansion-card rails | 3 | expansion-card cage |
| 4 | riser securing tabs (6) | 5 | riser securing slots (6) | | |

Installing the Left Riser Board

⚠ CAUTION: Only trained service technicians are authorized to remove the system cover and access any of the components inside the system. See your *Product Information Guide* for complete information about safety precautions, working inside the computer, and protecting against electrostatic discharge.

- 1 Place the riser board in the expansion-card cage so that the six securing tabs are fully inserted in the six securing slots on the riser board. See Figure 3-31.
- 2 Slide the riser board toward the expansion card openings until you feel the riser-board release pin snap into place.
- 3 Replace the expansion-card cage. See "Replacing the Expansion-Card Cage" on page 79.
- 4 Install all expansion cards in the expansion-card slots. See "Installing an Expansion Card" on page 76.
- 5 Close the system. See "Closing the System" on page 55.

Removing the Central Riser Board

⚠ CAUTION: Only trained service technicians are authorized to remove the system cover and access any of the components inside the system. See your *Product Information Guide* for complete information about safety precautions, working inside the computer, and protecting against electrostatic discharge.

- 1 Press the blue release tab in the center of the central riser to release the board from the system board socket while easing both ends of the riser upward.
- 2 Lift the central riser board from the two guide pins on either end, and draw the riser away from the system board.

Figure 3-32. Replacing the Central Riser Board

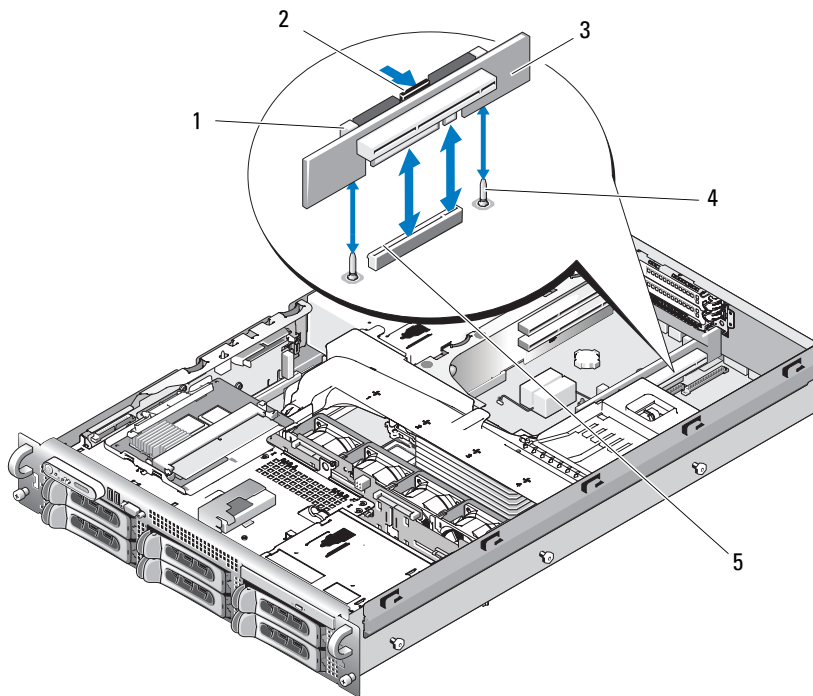

1 card guide (2)

2 release tab

3 central riser board

4 guide pins (2)

5 system board socket

Installing the Central Riser Board

- 1 Fitting the two guides over the guide pins on the system board, gently lower the central riser board until the board connector is firmly seated into the system board socket. See Figure 3-32.

Sideplane Board

Removing the Sideplane Board



CAUTION: Only trained service technicians are authorized to remove the system cover and access any of the components inside the system. See your *Product Information Guide* for complete information about safety precautions, working inside the computer, and protecting against electrostatic discharge.

- 1 Turn off the system and attached peripherals, and disconnect the system from the electrical outlet.
- 2 Open the system. See "Opening the System" on page 54.
- 3 Remove the SAS controller daughter card. See "Removing a SAS Controller Daughter Card" on page 74.
- 4 Remove any cables from the sideplane board.
- 5 Pressing inward on the sideplane release tabs, lift the sideplane up and away from the system. See Figure 3-33

Figure 3-33. Sideplane Removal and Installation

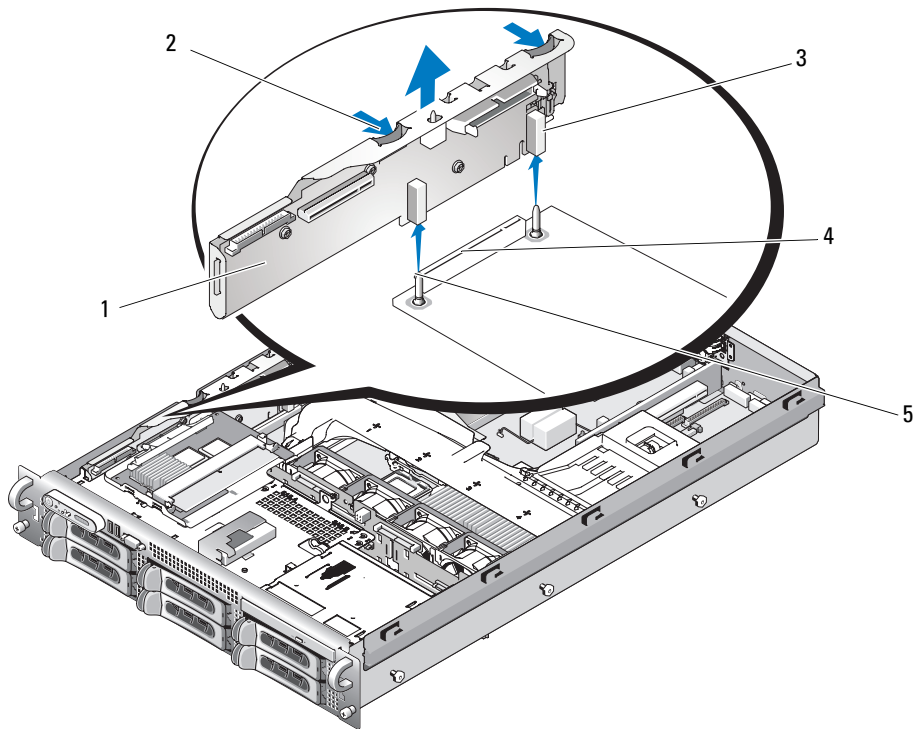

- | | | | | | |
|---|---------------------|---|----------------------------|---|------------|
| 1 | sideplane board | 2 | sideplane release tabs (2) | 3 | guides (2) |
| 4 | backplane connector | 5 | pins (2) | | |

Installing the Sideplane Board

CAUTION: Only trained service technicians are authorized to remove the system cover and access any of the components inside the system. See your *Product Information Guide* for complete information about safety precautions, working inside the computer, and protecting against electrostatic discharge.

- 1 Turn off the system and attached peripherals, and disconnect the system from the electrical outlet.
- 2 Align the two guides on the sideplane board with the two pins on the SAS backplane board, and gently lower the sideplane so that the sideplane connector is fully seated into the SAS backplane board connector. See Figure 3-33.
- 3 Reattach any cables to the sideplane board.
- 4 If applicable, replace the storage controller daughter card. See "Installing a SAS Controller Daughter Card" on page 70.
- 5 Close the system. See "Closing the System" on page 55.

SAS Backplane Board

Removing the SAS Backplane Board

 **CAUTION:** Only trained service technicians are authorized to remove the system cover and access any of the components inside the system. See your *Product Information Guide* for complete information about safety precautions, working inside the computer, and protecting against electrostatic discharge.

- 1 Turn off the system and attached peripherals, and disconnect the system from the electrical outlet.
- 2 Open the system. See "Opening the System" on page 54.
- 3 If applicable, disconnect the optical drive from the SAS backplane board. See "Removing the Optical Drive" on page 81.
- 4 If applicable, disconnect the diskette drive. See "Removing the Diskette Drive From the System" on page 83.
- 5 If applicable, disconnect the tape drive. See "Removing and Installing an Internal SCSI Tape Drive" on page 86.
- 6 Remove the hard drives. See "Removing a Hot-Plug Hard Drive" on page 57.

 **NOTE:** To properly reinstall the hard drives, ensure that you record which hard drive you remove from which bay.

- 7 Disconnect the SAS cable(s) and control panel cable from the backplane connectors. See "SAS and SAS RAID Controller Daughter Card Cabling Guidelines" on page 72 and "Removing the Control Panel Assembly" on page 105.
- 8 If applicable, remove the storage controller daughter card. See "Removing a SAS Controller Daughter Card" on page 74.
- 9 Remove the cooling shroud. See "Removing the Cooling Shroud" on page 67.
- 10 Remove the fans. See "Removing a System Fan" on page 65
- 11 Remove the fan bracket. See "Removing the Fan Bracket" on page 68.
- 12 Remove the SAS backplane board:
 - a Pull the SAS-backplane board release pin. See Figure 3-34.
 - b While pulling the release pin, tilt the backplane board toward the back of the system.
 - c Lift the backplane board from its securing tabs and remove the backplane board from the chassis.

Figure 3-34. SAS Backplane Board Removal

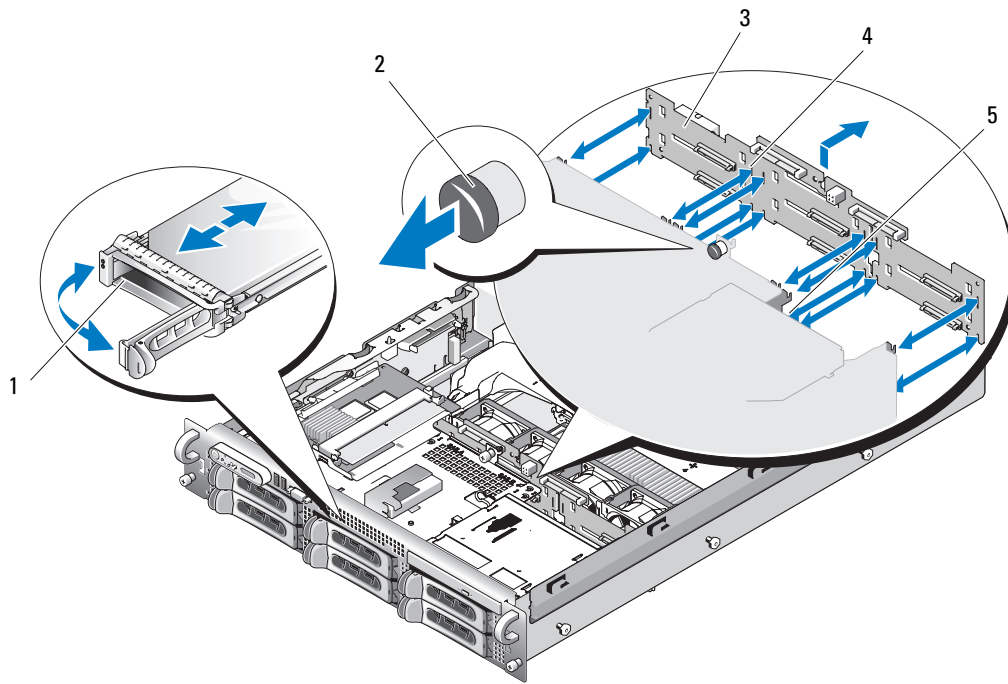

- | | | | | | |
|---|---------------------|---|-----------------------------|---|-------------------------|
| 1 | drive carrier | 2 | SAS-backplane board release | 3 | SAS backplane board pin |
| 4 | securing slots (10) | 5 | securing tabs (10) | | |

Installing the SAS Backplane Board

CAUTION: Only trained service technicians are authorized to remove the system cover and access any of the components inside the system. See your *Product Information Guide* for complete information about safety precautions, working inside the computer, and protecting against electrostatic discharge.

- 1 Place the SAS backplane board so that the securing tabs on the drive cage are fully inserted into the securing slots on the backplane board. See Figure 3-34.
- 2 Pull the SAS-backplane board release pin. See Figure 3-34.
- 3 While pulling the release pin, tilt the SAS-backplane board toward the front of the system until it stops, then release the release pin and ensure that it snaps into place.
- 4 Replace the fan bracket. See "Replacing the Fan Bracket" on page 69.
- 5 Replace the fans. See "Replacing a Cooling Fan" on page 66.
- 6 Replace the cooling shroud. See "Installing the Cooling Shroud" on page 67.

- 7 Reinstall the SAS controller daughter card. See "Installing a SAS Controller Daughter Card" on page 70.
- 8 Reattach the SAS controller daughter card cables and the control panel cable. See "SAS and SAS RAID Controller Daughter Card Cabling Guidelines" on page 72.
- 9 Reinstall the hard drives. See "Installing a Hot-Plug Hard Drive" on page 57.
 -  **NOTE:** Reinstall the hard drives in the same drive bays from which they were removed.
- 10 If applicable, reconnect the internal tape drive. See "Removing and Installing an Internal SCSI Tape Drive" on page 86.
- 11 If applicable, reconnect the diskette drive. See "Installing the Diskette Drive Into the System" on page 84.
- 12 If applicable, reconnect the optical drive. See "Installing the Optical Drive" on page 82.
- 13 Close the system. See "Closing the System" on page 55.

Control Panel Assembly (Service-only Procedure)

 **NOTE:** The control panel assembly consists of two separate modules—the display module and the control panel circuit board. Use the following instructions to remove and install either module.

Removing the Control Panel Assembly

 **CAUTION:** Only trained service technicians are authorized to remove the system cover and access any of the components inside the system. See your *Product Information Guide* for complete information about safety precautions, working inside the computer, and protecting against electrostatic discharge.

- 1 If applicable, remove the bezel. See "Removing the Front Bezel" on page 53.
- 2 Turn off the system and attached peripherals, and disconnect the system from the electrical outlet and peripherals.
- 3 Open the system. See "Opening the System" on page 54.
- 4 Disconnect the control panel cable at back of the control panel board. See Figure 3-35.
-  **NOTICE:** Do not pull on the cable to unseat the connector. Doing so can damage the cable.
 - a Squeeze the metal tabs on the ends of the cable connector.
 - b Gently work the connector out of the socket.
- 5 Disconnect the display module cable from the control panel board. See Figure 3-35.
- 6 Remove the three screws that secure the control panel board to the system chassis and remove the board. See Figure 3-35.
- 7 Remove the display module:
 - a Insert the end of paper clip into the hole on the right side of the display module and gently pry off the label.

- b Using a T10 Torx driver, remove the two screws that secure the display module to the system chassis.
- c Remove the display module from the chassis cutout.

Figure 3-35. Control Panel Removal

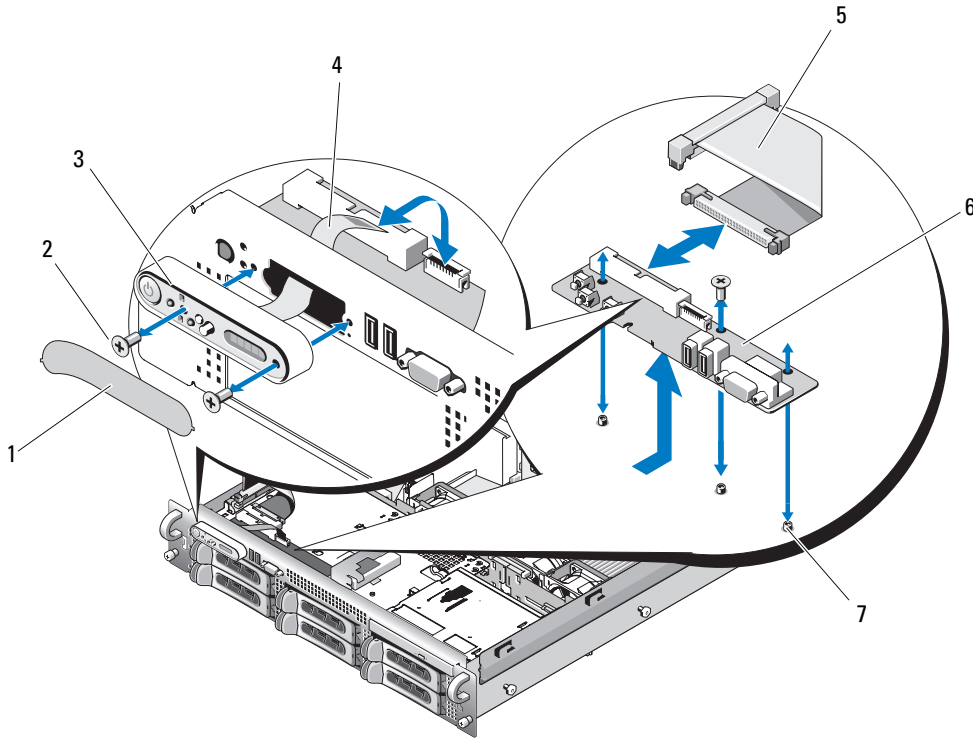

- | | | | | | |
|---|---|---|------------------------------------|---|-----------------------------|
| 1 | display module label | 2 | display module securing screws (2) | 3 | display module |
| 4 | display module cable | 5 | control panel cable | 6 | control panel circuit board |
| 7 | control-panel circuit board securing screws (3) | | | | |

Installing the Control Panel Assembly

- 1 Insert the display module into the chassis cutout and secure with the two Torx screws.
- 2 Affix the display module label to the display module.
- 3 Install the control panel board in the system chassis and secure with the three Phillips screws. See Figure 3-35.

- 4 Connect the display module cable to the control panel board. See Figure 3-35.
- 5 Connect the control panel cable to the control panel board. See Figure 3-35.
- 6 Close the system. See "Closing the System" on page 55.
- 7 Reconnect the system to the power source and turn on the system and attached peripherals.
- 8 If applicable, install the bezel.

System Board (Service-only Procedure)

Removing the System Board

 **CAUTION: Only trained service technicians are authorized to remove the system cover and access any of the components inside the system. See your *Product Information Guide* for complete information about safety precautions, working inside the computer, and protecting against electrostatic discharge.**

- 1 Turn off the system and attached peripherals, and disconnect the system from the electrical outlet.
- 2 Open the system. See "Opening the System" on page 54
- 3 If applicable, remove any expansion cards. See "Installing an Expansion Card" on page 77
- 4 Remove the expansion-card cage. See "Removing the Expansion-Card Cage" on page 78
- 5 Remove the cooling shroud. See "Removing the Cooling Shroud" on page 67.
- 6 Remove the fans. See "Removing a System Fan" on page 65.
- 7 Remove the fan bracket. See "Removing the Fan Bracket" on page 68
- 8 If applicable, remove the RAC card. See "Installing a RAC Card" on page 80

 **CAUTION: The DIMMs are hot to the touch for some time after the system has been powered down. Allow time for the DIMMs to cool before handling them. Handle the DIMMs by the card edges and avoid touching the DIMM components.**

- 9 Remove the memory modules. See "Removing Memory Modules" on page 92.

 **NOTE:** While removing the memory modules, record the memory module socket locations to ensure proper installation.

- 10 Remove the heatsink(s) and microprocessor(s). See "Removing a Processor" on page 93.
- 11 Remove the TOE key, if present. See Figure 6-2 for the location of the TOE key.
- 12 Remove the sideplane. See "Removing the Sideplane Board" on page 101.
- 13 Remove the SAS backplane. See "Removing the SAS Backplane Board" on page 103.
- 14 Remove the system board:
 - a Pull the system-board tray riser release pin. See Figure 3-36.
 - b While pulling the release pin, slide the system-board tray toward the front of the chassis.
 - c Lift up the system-board tray and remove it from the chassis.

Figure 3-36. System Board Removal

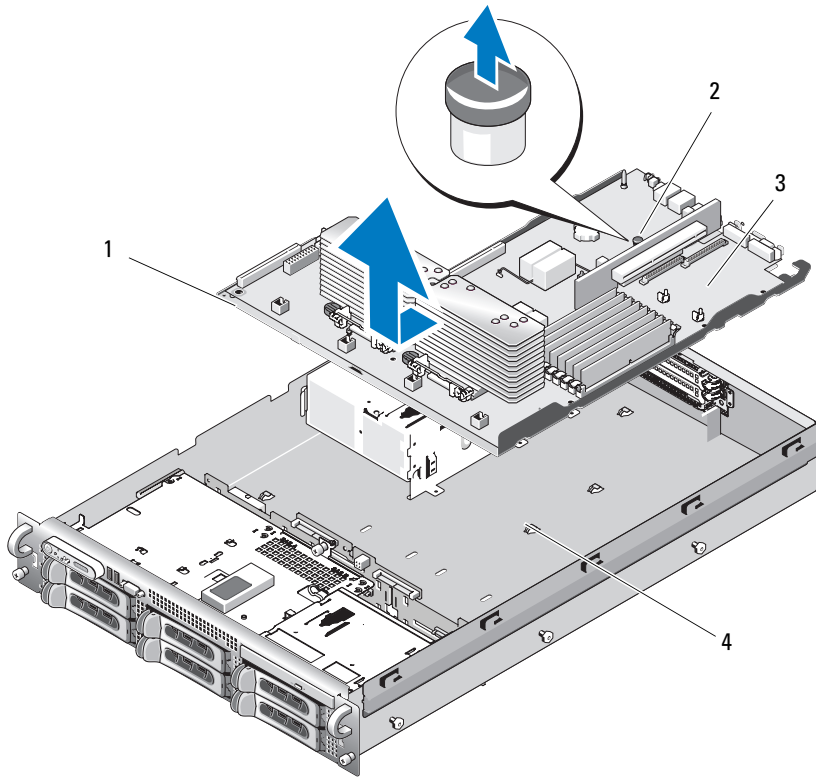

- 1 system-board tray
- 2 system-board tray riser release pin
- 3 system board
- 4 system-board securing tabs

Installing the System Board

CAUTION: Only trained service technicians are authorized to remove the system cover and access any of the components inside the system. See your *Product Information Guide* for complete information about safety precautions, working inside the computer, and protecting against electrostatic discharge.

- 1 Lower the system-board tray until the tray sits flat on the bottom of the chassis.
- 2 Ensure that all 17 system-board securing tabs are fully inserted into the 17 system-board securing slots. See Figure 3-36.
- 3 Slide the system-board tray toward the back of the chassis until it locks into position.
- 4 Replace the SAS backplane. See "Installing the SAS Backplane Board" on page 104.

- 5** Replace the sideplane. See "Installing the Sideplane Board" on page 102
- 6** Reinstall the TOE key, if applicable. See Figure 6-2 for the TOE key's location.
- 7** Replace the heatsink(s) and microprocessor(s). See "Installing a Processor" on page 95.
- 8** Replace the memory modules. See "Installing Memory Modules" on page 90.
- 9** If applicable, replace the RAC card. See "Installing a RAC Card" on page 80.
- 10** Replace the fan bracket. See "Replacing the Fan Bracket" on page 69.
- 11** Replace the fans. See "Replacing a Cooling Fan" on page 66.
- 12** Replace the cooling shroud. See "Installing the Cooling Shroud" on page 67.
- 13** Replace the expansion-card cage. See "Replacing the Expansion-Card Cage" on page 79.
- 14** If applicable, replace any expansion cards. See "Installing an Expansion Card" on page 76.
- 15** Close the system. See "Closing the System" on page 55.

Troubleshooting Your System

Safety First—For You and Your System

To perform certain procedures in this document, you must remove the system cover and work inside the system. While working inside the system, do not attempt to service the system except as explained in this guide and elsewhere in your system documentation.

⚠ CAUTION: Only trained service technicians are authorized to remove the system cover and access any of the components inside the system. Before performing any procedure, see your *Product Information Guide* for complete information about safety precautions, working inside the computer and protecting against electrostatic discharge.

Start-Up Routine

Look and listen during the system's start-up routine for the indications described in Table 1-1.

Table 4-1. Start-Up Routine Indications

Look/listen for:	Action
A status or error message displayed on the front-panel LCD.	See "LCD Status Messages" on page 19.
An error message displayed on the monitor.	See "System Messages" on page 28.
Alert messages from the systems management software.	See the systems management software documentation.
The monitor's power indicator.	See "Troubleshooting the Video Subsystem" on page 113.
The keyboard indicators.	See "Troubleshooting the Keyboard" on page 113.
The USB diskette drive activity indicator.	See "Troubleshooting a USB Device" on page 115.
The USB CD drive activity indicator.	See "Troubleshooting a USB Device" on page 115.
The diskette drive activity indicator.	See "Troubleshooting a Diskette Drive" on page 121.
The CD drive activity indicator.	See "Troubleshooting an Optical Drive" on page 123.
The hard-drive activity indicator.	See "Troubleshooting a Hard Drive" on page 124.
An unfamiliar constant scraping or grinding sound when you access a drive.	See "Getting Help" on page 147.

Checking the Equipment

This section provides troubleshooting procedures for external devices attached to the system, such as the monitor, keyboard, or mouse. Before you perform any of the procedures, see "Troubleshooting External Connections" on page 112.

Troubleshooting IRQ Assignment Conflicts

Most PCI devices can share an IRQ with another device, but they cannot use an IRQ simultaneously. To avoid this type of conflict, see the documentation for each PCI device for specific IRQ requirements. Table 4-2 lists the IRQ assignments.

Table 4-2. IRQ Assignment Defaults

IRQ Line	Assignment
IRQ0	System timer
IRQ1	Keyboard controller
IRQ2	Interrupt controller 1 to enable IRQ8 through IRQ15
IRQ3	Serial port 2 (COM2 and COM4)
IRQ4	Serial port 1 (COM1 and COM3)
IRQ5	Remote access controller
IRQ6	Diskette drive controller
IRQ7	Reserved
IRQ8	Real-time clock
IRQ9	ACPI functions (used for power management)
IRQ10	<i>Available</i>
IRQ11	<i>Available</i>
IRQ12	PS/2 mouse port unless the mouse is disabled through the System Setup program
IRQ13	Math coprocessor
IRQ14	IDE CD drive controller
IRQ15	<i>Available</i>

Troubleshooting External Connections

Loose or improperly connected cables are the most likely source of problems for the system, monitor, and other peripherals (such as a printer, keyboard, mouse, or other external device). Ensure that all external cables are securely attached to the external connectors on your system. See "Front-Panel Features and Indicators" on page 13 and "Back-Panel Features and Indicators" on page 17 for the front- and back-panel connectors on your system.

Troubleshooting the Video Subsystem

Problem

- Monitor is not working properly.
- Video memory is faulty.

Action

1 Check the system and power connections to the monitor.

2 Determine whether the system has an expansion card with a video output connector.

In this system configuration, the monitor cable should normally be connected to the connector on the expansion card, *not* to the system's integrated video connector.

To verify that the monitor is connected to the correct video connector, turn off the system and wait for 1 minute, then connect the monitor to the other video connector and turn the system on again.

3 Determine whether the system has monitors attached to both the front and rear video connectors.

The system supports only one monitor attached to either the front or rear video connector. When a monitor is connected to the front panel, the back-panel video, and PS/2 keyboard and mouse connectors are disabled.

If two monitors are attached to the system, disconnect one monitor. If the problem is not resolved, continue to the next step.

4 Run the appropriate online diagnostic test. See "Using Server Administrator Diagnostics" on page 131.

If the tests run successfully, the problem is not related to video hardware.

If the tests fail, see "Getting Help" on page 147.

Troubleshooting the Keyboard

Problem

- System message indicates a problem with the keyboard
- Keyboard is not functioning properly

Action

1 Enter the System Setup program and ensure that the USB ports are enabled. See "Using the System Setup Program" on page 37.

2 Examine the keyboard and its cable for signs of damage.

3 Swap the faulty keyboard with a working keyboard.

If the problem is resolved, replace the faulty keyboard. See "Getting Help" on page 147.

- 4 Run the appropriate online diagnostic test. See "Using Server Administrator Diagnostics" on page 131. If the problem is not resolved, see "Getting Help" on page 147.

Troubleshooting the Mouse

Problem

- System message indicates a problem with the mouse.
- Mouse is not functioning properly.

Action

- 1 Run the appropriate online diagnostic test. See "Using Server Administrator Diagnostics" on page 131. If the test fails, continue to the next step.
- 2 Examine the mouse and its cable for signs of damage. If the mouse is not damaged, go to step 4. If the mouse is damaged, continue to the next step.
- 3 Swap the faulty mouse with a working mouse. If the problem is resolved, replace the faulty mouse. See "Getting Help" on page 147.
- 4 Enter the System Setup program and ensure that the USB port is enabled. See "Using the System Setup Program" on page 37. If the problem is not resolved, see "Getting Help" on page 147.

Troubleshooting Basic I/O Functions

Problem

- Error message indicates a problem with a serial port.
- Device connected to a serial port is not operating properly.

Action

- 1 Enter the System Setup program and ensure that the serial port is enabled, and the serial port/COM ports are configured appropriately for any applications you are using. See "Using the System Setup Program" on page 37.
- 2 If the problem is confined to a particular application, see the application documentation for specific port configuration requirements that the program may require.
- 3 Run the appropriate online diagnostic test. See "Using Server Administrator Diagnostics" on page 131. If the tests run successfully but the problem persists, see "Troubleshooting a Serial I/O Device" on page 115.

Troubleshooting a Serial I/O Device

Problem

- Device connected to the serial port is not operating properly.

Action

- 1** Turn off the system and any peripheral devices connected to the serial port.
- 2** Swap the serial interface cable with a working cable, and turn on the system and the serial device.
If the problem is resolved, replace the interface cable.
- 3** Turn off the system and the serial device, and swap the device with a comparable device.
- 4** Turn on the system and the serial device.
If the problem is resolved, replace the serial device. See "Getting Help" on page 147.
If the problem persists, see "Getting Help" on page 147.

Troubleshooting a USB Device

Problem

- System message indicates a problem with a USB device.
- Device connected to a USB port is not operating properly.

Action

- 1** Enter the System Setup program, and ensure that the USB ports are enabled. See "Using the System Setup Program" on page 37.
- 2** Turn off the system and any USB devices.
- 3** Disconnect the USB devices, and connect the malfunctioning device to the other USB connector.
- 4** Turn on the system and the reconnected device.
If the problem is resolved, the USB connector might be defective. See "Getting Help" on page 147.
- 5** If possible, swap the interface cable with a working cable.
If the problem is resolved, replace the interface cable. See "Getting Help" on page 147.
- 6** Turn off the system and the USB device, and swap the device with a comparable device.
- 7** Turn on the system and the USB device.
If the problem is resolved, replace the USB device. See "Getting Help" on page 147.
If the problem persists, see "Getting Help" on page 147.

Troubleshooting a NIC

Problem

- NIC cannot communicate with network.

Action

- 1 Run the appropriate online diagnostic test. See "Running the System Diagnostics" on page 132.
- 2 Check the appropriate indicator on the NIC connector. See "NIC Indicator Codes" on page 19.
 - If the link indicator does not light, check all cable connections.
 - If the activity indicator does not light, the network driver files might be damaged or missing. Remove and reinstall the drivers if applicable. See the NIC's documentation.
 - Change the autonegotiation setting, if possible.
 - Use another connector on the switch or hub.

If you are using a NIC card instead of an integrated NIC, see the documentation for the NIC card.

- 3 Ensure that the appropriate drivers are installed and the protocols are bound. See the NIC's documentation.
- 4 Enter the System Setup program and confirm that the NICs are enabled. See "Using the System Setup Program" on page 37.
- 5 Ensure that the NICs, hubs, and switches on the network are all set to the same data transmission speed. See the network equipment documentation.
- 6 Ensure that all network cables are of the proper type and do not exceed the maximum length. See Network Cable Requirements in your *Getting Started Guide*.

Troubleshooting a Wet System

Problem

- Liquid spilled on the system.
- Excessive humidity.

Action



CAUTION: Only trained service technicians are authorized to remove the system cover and access any of the components inside the system. Before performing any procedure, see your *Product Information Guide* for complete information about safety precautions, working inside the computer and protecting against electrostatic discharge.

- 1 Turn off the system and attached peripherals, and disconnect the system from the electrical outlet.
- 2 Open the system. See "Opening and Closing the System" on page 54.

- 3 Remove all expansion cards installed in the system. See "Removing an Expansion Card" on page 78.
- 4 Let the system dry thoroughly for at least 24 hours.
- 5 Close the system. See "Opening and Closing the System" on page 54.
- 6 Reconnect the system to the electrical outlet, and turn on the system and attached peripherals.
If the system does not start properly, see "Getting Help" on page 147.
- 7 If the system starts properly, shut down the system and reinstall all of the expansion cards that you removed. See "Installing an Expansion Card" on page 76.
- 8 Run the appropriate online diagnostic test. See "Using Server Administrator Diagnostics" on page 131.
If the tests fail, see "Getting Help" on page 147.

Troubleshooting a Damaged System

Problem

- System was dropped or damaged.

Action



CAUTION: Only trained service technicians are authorized to remove the system cover and access any of the components inside the system. Before performing any procedure, see your *Product Information Guide* for complete information about safety precautions, working inside the computer and protecting against electrostatic discharge.

- 1 Open the system. See "Opening and Closing the System" on page 54.
- 2 Ensure that the following components are properly installed:
 - Expansion cards and risers
 - Power supplies
 - Fans
 - Processors and heat sinks
 - Memory modules
 - Drive-carrier connections to the SAS backplane board, if applicable
- 3 Ensure that all cables are properly connected.
- 4 Close the system. See "Opening and Closing the System" on page 54.
- 5 Run the system board tests in the system diagnostics. See "Running the System Diagnostics" on page 132.
If the tests fail, see "Getting Help" on page 147.

Troubleshooting the System Battery

Problem

- System message indicates a problem with the battery.
- System Setup program loses system configuration information.
- System date and time do not remain current.



NOTE: If the system is turned off for long periods of time (for weeks or months), the NVRAM may lose its system configuration information. This situation is caused by a defective battery.

Action

- 1 Re-enter the time and date through the System Setup program. See "Using the System Setup Program" on page 37.
- 2 Turn off the system and disconnect it from the electrical outlet for at least one hour.
- 3 Reconnect the system to the electrical outlet and turn on the system.
- 4 Enter the System Setup program.

If the date and time are not correct in the System Setup program, replace the battery. See "System Battery" on page 96.

If the problem is not resolved by replacing the battery, see "Getting Help" on page 147.



NOTE: Some software may cause the system time to speed up or slow down. If the system seems to operate normally except for the time kept in the System Setup program, the problem may be caused by software rather than by a defective battery.

Troubleshooting Power Supplies

Problem

- System-status indicators are amber.
- Power-supply fault indicators are amber.
- Front-panel status LCD indicates a problem with the power supplies.

Action



CAUTION: Only trained service technicians are authorized to remove the system cover and access any of the components inside the system. Before performing any procedure, see your *Product Information Guide* for complete information about safety precautions, working inside the computer and protecting against electrostatic discharge.

- 1 Run the appropriate online diagnostics test. See "Using Server Administrator Diagnostics" on page 131.
- 2 Locate the faulty power supply.

The power supply's fault indicator is lit. See "Power Indicator Codes" on page 18.

-  **NOTICE:** You can hot-plug the power supplies. One power supply must be installed for the system to operate. The system is in the redundant mode when two power supplies are installed. Remove and install only one power supply at a time in a system that is powered on. Operating the system for extended periods of time with only one power supply installed, without a power supply blank installed, can cause the system to overheat.

Remove the faulty power supply. See "Removing a Power Supply" on page 63.

- 3 Ensure that the power supply is properly installed by removing and reinstalling it. See "Replacing a Power Supply" on page 64.

 **NOTE:** After installing a power supply, allow several seconds for the system to recognize the power supply and to determine if it is working properly. The power indicator turns green to signify that the power supply is functioning properly. See "Power Indicator Codes" on page 18.

- 4 Check the indicators to see if the problem is resolved. If not, remove the faulty power supply. See "Removing a Power Supply" on page 63.
- 5 Install a new power supply. See "Replacing a Power Supply" on page 64.
If the problem persists, see "Getting Help" on page 147.

Troubleshooting System Cooling Problems

Problem

- Systems management software issues a fan-related error message.

Action

Ensure that none of the following conditions exist:

- Ambient temperature is too high.
- External airflow is obstructed.
- Cables inside the system obstruct airflow.
- An individual cooling fan has failed. See "Troubleshooting a Fan" on page 119.

Troubleshooting a Fan

Problem

- System-status indicator is amber.
- Systems management software issues a fan-related error message.
- Front panel LCD indicates a problem with the fan.

Action

 **CAUTION: Only trained service technicians are authorized to remove the system cover and access any of the components inside the system. Before performing any procedure, see your *Product Information Guide* for complete information about safety precautions, working inside the computer and protecting against electrostatic discharge.**

- 1 Run the appropriate diagnostic test. See "Using Server Administrator Diagnostics" on page 131.
- 2 Open the system. See "Opening and Closing the System" on page 54.

 **CAUTION: The cooling fans are hot-pluggable. To maintain proper cooling while the system is on, only replace one fan at a time.**

- 3 Locate the faulty fan indicated by the LCD display or diagnostic software. For the identification number of each fan, see Figure 3-9.
- 4 Ensure that the faulty fan's power cable is firmly attached to the fan power connector. See "System Fans" on page 65.

 **NOTE:** Wait 30 seconds for the system to recognize the fan and determine whether it is working properly.

- 5 If the problem is not resolved, install a new fan. See "System Fans" on page 65.

If the replacement fan is working properly, close the system. See "Opening and Closing the System" on page 54.

If the replacement fan does not operate, see "Getting Help" on page 147.

Troubleshooting System Memory

Problem

- Faulty memory module.
- Faulty system board.
- Front-panel status LCD indicates a problem with system memory.

Action

 **CAUTION: Only trained service technicians are authorized to remove the system cover and access any of the components inside the system. Before performing any procedure, see your *Product Information Guide* for complete information about safety precautions, working inside the computer and protecting against electrostatic discharge.**

- 1 Run the appropriate online diagnostic test. See "Using Server Administrator Diagnostics" on page 131.
- 2 Turn on the system and attached peripherals.

If an error message does not appear, continue to the next step.

If an error messages appears, go to step 11.

- 3 Enter the System Setup program and check the system memory setting. See "Entering the System Setup Program" on page 37.

If the amount of memory installed matches the system memory setting, go to step 11.

- 4 Remove the bezel. See "Front Bezel" on page 53.
- 5 Turn off the system and attached peripherals, and disconnect the system from the electrical outlet.
- 6 Open the system. See "Opening and Closing the System" on page 54.
- 7 Reseat the memory modules in their sockets. See "Installing Memory Modules" on page 90.
- 8 Close the system. See "Opening and Closing the System" on page 54.
- 9 Reconnect the system to its electrical outlet, and turn on the system and attached peripherals.
- 10 Enter the System Setup program and check the system memory setting. See "Using the System Setup Program" on page 37.

If the amount of memory installed does not match the system memory setting, then perform the following steps:

- a Turn off the system and attached peripherals, and disconnect the system from its electrical outlet.
- b Open the system. See "Opening and Closing the System" on page 54.

 **NOTE:** Several configurations for memory modules exist; see "General Memory Module Installation Guidelines" on page 89.

- c Swap the memory module in socket 1 with another of the same capacity. See "Installing Memory Modules" on page 90.
- d Close the system. See "Opening and Closing the System" on page 54.
- e Reconnect the system to its electrical outlet, and turn on the system and attached peripherals.
- f As the system boots, observe the monitor screen and the indicators on the keyboard.
- 11 Perform the following steps:
 - a Turn off the system and attached peripherals, and disconnect the system from its electrical outlet.
 - b Open the system. See "Opening and Closing the System" on page 54.
 - c Perform step c through step f in step 10 for each memory module installed.

If the problem persists, see "Getting Help" on page 147.

Troubleshooting a Diskette Drive

Problem

- Error message indicates a diskette drive problem.

Action



CAUTION: Only trained service technicians are authorized to remove the system cover and access any of the components inside the system. Before performing any procedure, see your *Product Information Guide* for complete information about safety precautions, working inside the computer and protecting against electrostatic discharge.

- 1 Enter the System Setup program and verify that the diskette drive is configured correctly. See "Using the System Setup Program" on page 37.
- 2 Open or remove the bezel. See "Front Bezel" on page 53.
- 3 Run the appropriate online diagnostic test. See "Using Server Administrator Diagnostics" on page 131.
- 4 Turn off the system and attached peripherals, and disconnect the system from the electrical outlet.
- 5 Open the system. See "Opening and Closing the System" on page 54.
- 6 Ensure that the diskette drive interface cable is securely connected to the diskette drive and the system board.
- 7 Ensure that a power cable is properly connected to the drive.
- 8 Close the system. See "Opening and Closing the System" on page 54.
- 9 Reconnect the system to the electrical outlet, and turn on the system and attached peripherals.
- 10 Run the appropriate online diagnostic test to see whether the diskette drive works correctly.
- 11 Turn off the system and attached peripherals, and disconnect the system from its electrical outlet.
- 12 Open the system. See "Opening and Closing the System" on page 54.
- 13 Remove all expansion cards installed in the system. See "Removing an Expansion Card" on page 78.
- 14 Close the system. See "Opening and Closing the System" on page 54.
- 15 Reconnect the system to the electrical outlet, and turn on the system and attached peripherals.
- 16 Run the appropriate online diagnostic test to see whether the diskette drive works correctly.
If the tests run successfully, an expansion card may be conflicting with the diskette drive logic, or an expansion card may be faulty. Continue to the next step.
If the tests fail, see "Getting Help" on page 147.
- 17 Turn off the system and attached peripherals, and disconnect the system from the electrical outlet.
- 18 Open the system. See "Opening and Closing the System" on page 54.
- 19 Reinstall one of the expansion cards you removed in step 13. See "Installing an Expansion Card" on page 76.
- 20 Close the system. See "Opening and Closing the System" on page 54.
- 21 Reconnect the system to the electrical outlet, and turn on the system and attached peripherals.
- 22 Run the appropriate online diagnostic test to see whether the diskette drive works correctly.

- 23** Repeat step 17 through step 23 until all expansion cards are reinstalled or one of the expansion cards causes the tests to fail.

If the problem is not resolved, see "Getting Help" on page 147.

Troubleshooting an Optical Drive

Problem

- System cannot read data from a CD or DVD in an optical drive.
- Optical drive indicator does not blink during boot.

Action



CAUTION: Only trained service technicians are authorized to remove the system cover and access any of the components inside the system. Before performing any procedure, see your *Product Information Guide* for complete information about safety precautions, working inside the computer and protecting against electrostatic discharge.

- 1** Try using a different CD or DVD that you know works properly.
 - 2** Enter the System Setup program and ensure that the drive's IDE controller is enabled. See "Using the System Setup Program" on page 37.
 - 3** Run the appropriate online diagnostic test. See "Using Server Administrator Diagnostics" on page 131.
 - 4** Turn off the system and attached peripherals, and disconnect the system from the electrical outlet.
 - 5** Open the system. See "Opening and Closing the System" on page 54.
 - 6** Ensure that the interface cable is securely connected to the optical drive and to the sideplane.
 - 7** Ensure that a power cable is properly connected to the drive.
 - 8** Close the system. See "Opening and Closing the System" on page 54.
 - 9** Reconnect the system to the electrical outlet, and turn on the system and attached peripherals.
- If the problem is not resolved, see "Getting Help" on page 147.

Troubleshooting an External SCSI Tape Drive

Problem

- Defective tape drive
- Defective tape cartridge
- Missing or corrupted tape-backup software or tape drive device driver
- Defective SCSI controller

Action

- 1 Remove the tape cartridge you were using when the problem occurred, and replace it with a tape cartridge that you know works.
- 2 Ensure that the SCSI device drivers for the tape drive are installed and are configured correctly. See "Removing and Installing an Internal SCSI Tape Drive" on page 86.
- 3 Reinstall the tape-backup software as instructed in the tape-backup software documentation.
- 4 Ensure that the tape drive's interface/DC power cable is connected to the tape drive and SCSI controller card.
- 5 Verify that the tape drive is configured for a unique SCSI ID number and that the tape drive is terminated or not terminated, based on the interface cable used to connect the drive.
See the documentation for the tape drive for instructions on selecting the SCSI ID number and enabling or disabling termination.
- 6 Run the appropriate online diagnostics tests. See "Using Server Administrator Diagnostics" on page 131.
- 7 Open or remove the bezel. See "Front Bezel" on page 53.
- 8 Turn off the system and attached peripherals, and disconnect the system from the electrical outlet.



CAUTION: Only trained service technicians are authorized to remove the system cover and access any of the components inside the system. Before performing any procedure, see your *Product Information Guide* for complete information about safety precautions, working inside the computer and protecting against electrostatic discharge.

- 9 Open the system. See "Opening and Closing the System" on page 54.
- 10 Ensure that the SCSI controller card is firmly seated in its connector. See "Installing an Expansion Card" on page 76.
- 11 Close the system. See "Opening and Closing the System" on page 54.
- 12 Reconnect the system to the electrical outlet, and turn on the system, including attached peripherals.
- 13 If the problem is not resolved, see the documentation for the tape drive for additional troubleshooting instructions.
- 14 If you cannot resolve the problem, see "Getting Help" on page 147 for information on obtaining technical assistance.

Troubleshooting a Hard Drive

Problem

- Device driver error.
- One or more hard drives not recognized by the system.

Action



CAUTION: Only trained service technicians are authorized to remove the system cover and access any of the components inside the system. Before performing any procedure, see your *Product Information Guide* for complete information about safety precautions, working inside the computer and protecting against electrostatic discharge.



NOTICE: This troubleshooting procedure can destroy data stored on the hard drive. Before you proceed, back up all files on the hard drive.

- 1 Run the appropriate online diagnostics test. See "Using Server Administrator Diagnostics" on page 131. Depending on the results of the diagnostics test, proceed as needed through the following steps.
- 2 Remove the bezel. See "Removing the Front Bezel" on page 53.
- 3 If you are experiencing problems with multiple hard drives, skip to step 8. For a problem with a single hard drive, continue to the next step.
- 4 Turn off your system, reseal the hard drive, and restart the system.
- 5 If your system has a SAS RAID controller daughter card, perform the following steps.
 - a Restart the system and press <Ctrl><R> to enter the host adapter configuration utility program. See the documentation supplied with the host adapter for information about the configuration utility.
 - b Ensure that the hard drive has been configured correctly for the RAID.
 - c Exit the configuration utility and allow the system to boot to the operating system.
- 6 Ensure that the required device drivers for your controller daughter card are installed and are configured correctly. See the operating system documentation for more information.



NOTICE: Do not perform the following step if you have a SAS RAID controller daughter card.

- 7 If you have the non-RAID SAS controller daughter card, remove the hard drive and swap its drive bay location with another hard drive that is functioning properly.

If the problem is resolved, reinstall the hard drive in the original bay. See "Installing a Hot-Plug Hard Drive" on page 57.

If the hard drive functions properly in the original bay, the drive carrier could have intermittent problems. Replace the hard-drive carrier. See "Getting Help" on page 147.

If the hard drive functioned properly in another bay but does not function in the original bay, the SAS backplane has a defective connector. See "Getting Help" on page 147.

- 8 Check the cable connections inside the system:
 - a Turn off the system, including any attached peripherals, and disconnect the system from the electrical outlet.
 - b Open the system. See "Opening the System" on page 54.

- c Verify that the cable connections between SAS backplane(s) and the SAS daughter card are correct. See "Installing a SAS Controller Daughter Card" on page 70.
 - d Verify that the SAS cables are securely seated in their connectors.
 - e Verify that the power connectors on the SAS backplane(s) are securely seated in their connectors.
 - f Close the system. See "Closing the System" on page 55.
 - g Reconnect the system to the electrical outlet, and turn on the system and attached peripherals.
- If the problem persists, see "Getting Help" on page 147.

Troubleshooting a SAS or SAS RAID Controller Daughter Card



NOTE: When troubleshooting a SAS or SAS RAID controller daughter card, also see the documentation for your operating system and the controller daughter card.

Problem

- Error message indicates a problem with the SAS or SAS RAID controller daughter card.
- SAS or SAS RAID controller daughter card performs incorrectly or not at all.

Action



CAUTION: Only trained service technicians are authorized to remove the system cover and access any of the components inside the system. Before performing any procedure, see your *Product Information Guide* for complete information about safety precautions, working inside the computer and protecting against electrostatic discharge.

- 1 Run the appropriate online diagnostic test. See "Using Server Administrator Diagnostics" on page 131.
- 2 Enter the System Setup program and ensure that the SAS or SAS RAID controller daughter card is enabled. See "Using the System Setup Program" on page 37.
- 3 Restart the system and press the applicable key sequence to enter the configuration utility program:
 - <Ctrl><C> for a SAS controller
 - <Ctrl><R> for a SAS RAID controller

See the controller's documentation for information about configuration settings.
- 4 Check the configuration settings, make any necessary corrections, and restart the system.
If the problem is not resolved, continue to the next step.
- 5 Remove the bezel. See "Removing the Front Bezel" on page 53.
- 6 Turn off the system and attached peripherals, and disconnect the system from its electrical outlet.
- 7 Open the system. See "Opening and Closing the System" on page 54.
- 8 Ensure that the controller card is firmly seated in its connector. See "SAS Controller Daughter Card" on page 69.

- 9 If you have a SAS RAID controller daughter card, ensure that the following RAID components are properly installed and connected:
 - Memory module
 - Battery
- 10 Verify that the cable connections between the SAS backplane(s) and the SAS controller daughter card are correct. See "Installing a SAS Controller Daughter Card" on page 70.
- 11 Ensure that the cables are firmly connected to the SAS controller daughter card and the SAS backplane board.
- 12 Close the system. See "Opening and Closing the System" on page 54.
- 13 Reconnect the system to its electrical outlet, and turn on the system and attached peripherals. If the problem persists, proceed as follows:
 - If you have a SAS controller daughter card, see "Getting Help" on page 147.
 - If you have a SAS RAID controller daughter card, replace the SAS RAID daughter card battery. See "Installing a RAID Battery" on page 74. If replacing the battery does not solve the problem, see "Getting Help" on page 147.

Troubleshooting Expansion Cards



NOTE: When troubleshooting an expansion card, see the documentation for your operating system and the expansion card.

Problem

- Error message indicates a problem with an expansion card.
- Expansion card performs incorrectly or not at all.

Action



CAUTION: Only trained service technicians are authorized to remove the system cover and access any of the components inside the system. Before performing any procedure, see your *Product Information Guide* for complete information about safety precautions, working inside the computer and protecting against electrostatic discharge.

- 1 Run the appropriate online diagnostic test. See "Using the System Setup Program" on page 37.
- 2 Open or remove the bezel. See "Front Bezel" on page 53.
- 3 Turn off the system and attached peripherals, and disconnect the system from the electrical outlet.
- 4 Open the system. See "Opening and Closing the System" on page 54.
- 5 Ensure that each expansion card is firmly seated in its connector. See "Installing an Expansion Card" on page 76.
- 6 Close the system. See "Opening and Closing the System" on page 54.

- 7 Reconnect the system to the electrical outlet, and turn on the system and attached peripherals.
If the problem persists, go to the next step.
- 8 Turn off the system and attached peripherals, and disconnect the system from the electrical outlet.
- 9 Open the system. See "Opening and Closing the System" on page 54.
- 10 Remove all expansion cards installed in the system. See "Removing an Expansion Card" on page 78.
- 11 Close the system. See "Opening and Closing the System" on page 54.
- 12 Reconnect the system to the electrical outlet, and turn on the system and attached peripherals.
- 13 Run the appropriate online diagnostic test.
If the tests fail, see "Getting Help" on page 147.
- 14 For each expansion card you removed in step 10, perform the following steps:
 - a Turn off the system and attached peripherals, and disconnect the system from the electrical outlet.
 - b Open the system. See "Opening and Closing the System" on page 54.
 - c Reinstall one of the expansion cards.
 - d Close the system. See "Opening and Closing the System" on page 54.
 - e Run the appropriate diagnostic test.
If the tests fail, see "Getting Help" on page 147.

Troubleshooting the Microprocessors

Problem

- Error message indicates a processor problem.
- Front-panel status LCD indicates a problem with the processors or system board.
- A heat sink is not installed for each processor.

Action



CAUTION: Only trained service technicians are authorized to remove the system cover and access any of the components inside the system. Before performing any procedure, see your *Product Information Guide* for complete information about safety precautions, working inside the computer and protecting against electrostatic discharge.

- 1 Run the appropriate online diagnostics test. See "Using Server Administrator Diagnostics" on page 131.
- 2 Turn off the system and attached peripherals, and disconnect the system from the electrical outlet.
- 3 Open the system. See "Opening and Closing the System" on page 54.
- 4 Ensure that each processor and heat sink are properly installed. See "Processors" on page 93.
- 5 Close the system. See "Opening and Closing the System" on page 54.

- 6** Reconnect the system to the electrical outlet, and turn on the system and attached peripherals.
- 7** Run the appropriate online diagnostic test.
If the tests fail or the problem persists, continue to the next step.
- 8** Turn off the system and attached peripherals, and disconnect the system from the electrical outlet.
- 9** Open the system. See "Opening and Closing the System" on page 54.
- 10** Remove processor 2, leaving only processor 1 installed. See "Processors" on page 93.
To locate the processors, see Figure 6-2.
If only one processor is installed, see "Getting Help" on page 147.
- 11** Close the system. See "Opening and Closing the System" on page 54.
- 12** Reconnect the system to the electrical outlet, and turn on the system and attached peripherals.
- 13** Run the appropriate online diagnostic test.
If the tests complete successfully, go to step 19.
- 14** Turn off the system and attached peripherals, and disconnect the system from the electrical outlet.
- 15** Open the system. See "Opening and Closing the System" on page 54.
- 16** Replace processor 1 with another processor of the same capacity. See "Processors" on page 93.
- 17** Close the system. See "Opening and Closing the System" on page 54.
- 18** Run the appropriate online diagnostic test.
If the tests complete successfully, replace processor 1. See "Getting Help" on page 147.
- 19** Turn off the system and attached peripherals, and disconnect the system from the electrical outlet.
- 20** Open the system. See "Opening and Closing the System" on page 54.
- 21** Reinstall the processors that you removed in step 10. See "Processors" on page 93.
- 22** Close the system. See "Opening and Closing the System" on page 54.
- 23** Reconnect the system to the electrical outlet, and turn on the system and attached peripherals.
If the problem persists, see "Getting Help" on page 147.

Running the System Diagnostics

If you experience a problem with your system, run the diagnostics before calling for technical assistance. The purpose of the diagnostics is to test your system's hardware without requiring additional equipment or risking data loss. If you are unable to fix the problem yourself, service and support personnel can use diagnostics test results to help you solve the problem.

Using Server Administrator Diagnostics

To assess a system problem, first use the online Server Administrator diagnostics. If you are unable to identify the problem, then use the system diagnostics.

To access the online diagnostics, log into the Server Administrator home page, and then click the **Diagnostics** tab. For information about using diagnostics, see the online help. For additional information, see the *Server Administrator User's Guide*.

System Diagnostics Features

The system diagnostics provides a series of menus and options for particular device groups or devices. The system diagnostics menus and options allow you to:

- Run tests individually or collectively.
- Control the sequence of tests.
- Repeat tests.
- Display, print, or save test results.
- Temporarily suspend testing if an error is detected or terminate testing when a user-defined error limit is reached.
- View help messages that briefly describe each test and its parameters.
- View status messages that inform you if tests are completed successfully.
- View error messages that inform you of problems encountered during testing.

When to Use the System Diagnostics

If a major component or device in the system does not operate properly, component failure may be indicated. As long as the microprocessor and the system's input/output devices (monitor, keyboard, and diskette drive) are functioning, you can use the system diagnostics to help identify the problem.

Running the System Diagnostics

The system diagnostics is run from the utility partition on your hard drive.

 **NOTICE:** Use the system diagnostics to test only your system. Using this program with other systems may cause invalid results or error messages. In addition, use only the program that came with your system (or an updated version of that program).

- 1 As the system boots, press <F10> during POST.
- 2 From the utility partition main menu, select **Run System Diagnostics**, or select **Run Memory Diagnostics** if you are troubleshooting memory.

When you start the system diagnostics, a message is displayed stating that the diagnostics are initializing. Next, the **Diagnostics** menu appears. The menu allows you to run all or specific diagnostics tests or to exit the system diagnostics.

 **NOTE:** Before you read the rest of this section, start the system diagnostics so that you can see the utility on your screen.

System Diagnostics Testing Options

Click the testing option in the **Main Menu** window. Table 5-1 provides a brief explanation of testing options.

Table 5-1. System Diagnostics Testing Options

Testing Option	Function
Express Test	Performs a quick check of the system. This option runs device tests that do not require user interaction. Use this option to quickly identify the source of your problem.
Extended Test	Performs a more thorough check of the system. This test can take an hour or longer.
Custom Test	Tests a particular device.
Information	Displays test results.

Using the Custom Test Options

When you select **Custom Test** in the **Main Menu** window, the **Customize** window appears and allows you to select the device(s) to be tested, select specific options for testing, and view the test results.

Selecting Devices for Testing

The left side of the **Customize** window lists devices that can be tested. Devices are grouped by device type or by module, depending on the option you select. Click the (+) next to a device or module to view its components. Click (+) on any component to view the tests that are available. Clicking a device, rather than its components, selects all of the components of the device for testing.

Selecting Diagnostics Options

Use the **Diagnostics Options** area to select how you want to test a device. You can set the following options:

- **Non-Interactive Tests Only** — When checked, runs only tests that require no user intervention.
- **Quick Tests Only** — When checked, runs only the quick tests on the device. Extended tests will not run when you select this option.
- **Show Ending Timestamp** — When checked, time stamps the test log.
- **Test Iterations** — Selects the number of times the test is run.
- **Log output file pathname** — When checked, enables you to specify where the test log file is saved.

Viewing Information and Results

The tabs in the **Customize** window provide information about the test and the test results. The following tabs are available:

- **Results** — Displays the test that ran and the result.
- **Errors** — Displays any errors that occurred during the test.
- **Help** — Displays information about the currently selected device, component, or test.
- **Configuration** — Displays basic configuration information about the currently selected device.
- **Parameters** — If applicable, displays parameters that you can set for the test.

Jumpers and Connectors

This section provides specific information about the system jumpers and describes the connectors on the various boards in the system.

System Board Jumpers

Figure 6-1 shows the location of the configuration jumpers on the system board. Table 6-1 lists the jumper settings.



-  **NOTE:** To access the jumpers, remove the cooling shroud by lifting the release latch and sliding the shroud towards the front of the system. See Figure 3-10.
-  **NOTE:** Lift up the memory module airflow shroud for easy access to the jumpers.

Figure 6-1. System Board Jumpers

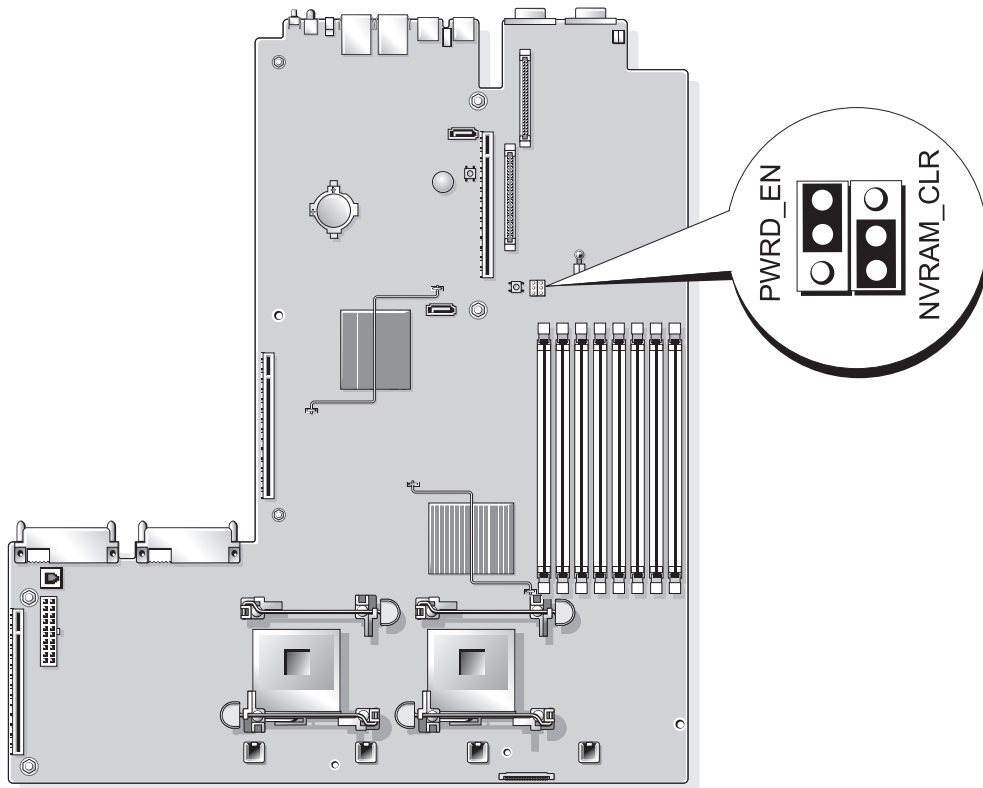





Table 6-1. System Board Jumper Settings

Jumper	Setting	Description
1 PWRD_EN	 (default)	The password feature is enabled.
		The password feature is disabled.
2 NVRAM_CLR	 (default)	The configuration settings are retained at system boot.
		The configuration settings are cleared at the next system boot. (If the configuration settings become corrupted to the point where the system will not boot, install the jumper and boot the system. Remove the jumper before restoring the configuration information.)

NOTE: For the full name of an abbreviation or acronym used in this table, see the "Glossary" on page 169.

System Board Connectors

See Figure 6-2 and Table 6-2 for the location and description of system board connectors.

Figure 6-2. System Board Connectors

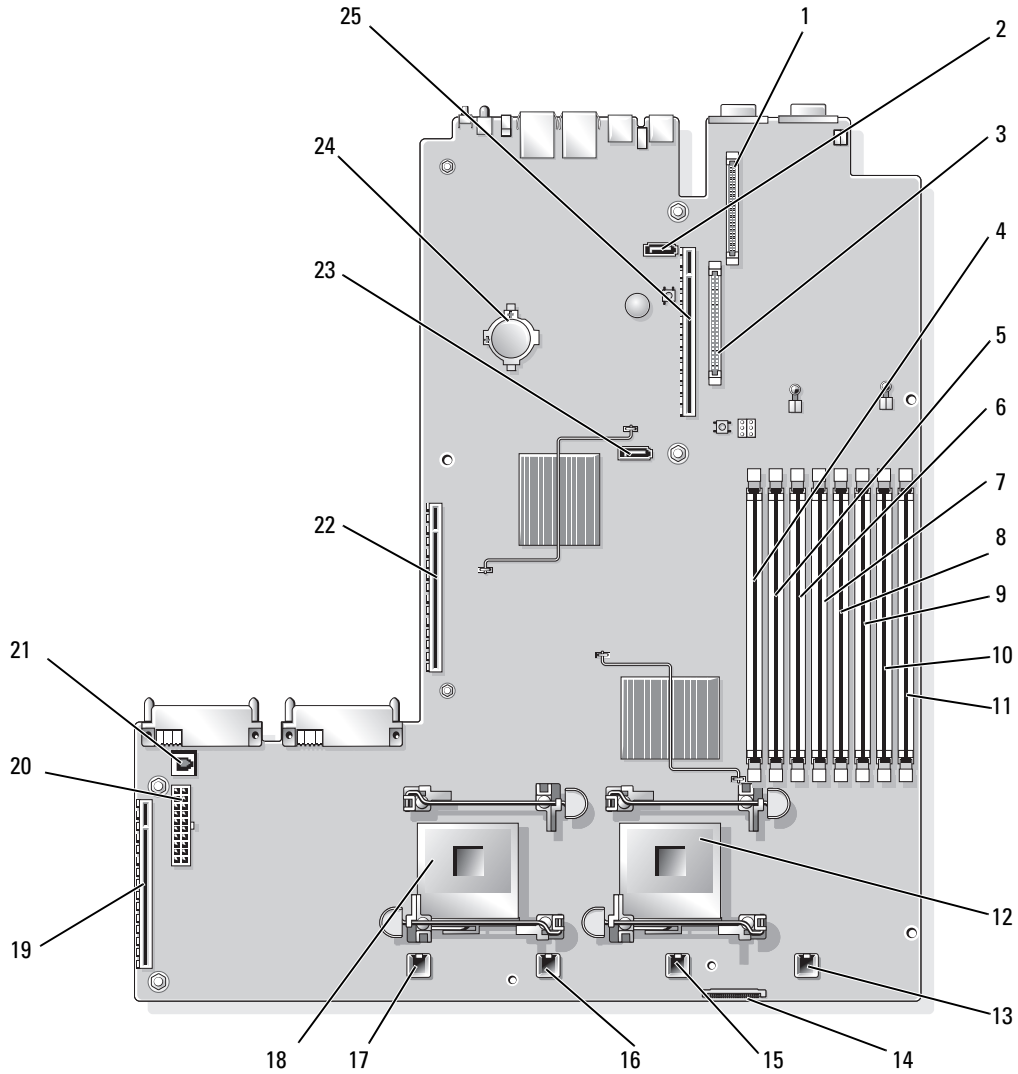

Table 6-2. System Board Connectors

	Connector	Description
1	RAC_CONN2	Remote Access Control (RAC) card 2
2	SATA_B	SATA B connector
3	RAC_CONN1	Remote Access Control (RAC) card 1
4	DIMM 1	Memory module, slot 1
5	DIMM 5	Memory module, slot 5
6	DIMM 2	Memory module, slot 2
7	DIMM 6	Memory module, slot 6
8	DIMM 3	Memory module, slot 3
9	DIMM 7	Memory module, slot 7
10	DIMM 4	Memory module, slot 4
11	DIMM 8	Memory module, slot 8
12	CPU1	Microprocessor 1
13	FAN4_2U	System cooling fan
14	FLOPPY	Floppy drive connector
15	FAN3_2U	System cooling fan
16	FAN2_2U	System cooling fan
17	FAN1_2U	System cooling fan
18	CPU2	Microprocessor 2
19	SIDEPLANE	Sideplane connector
20	BACKPLANE	Backplane power connector
21	TOE_KEY	TCP/IP Offload Engine Key
22	RISER1	Left riser board connector
23	SATA_A	SATA A connector
24	BATTERY	System battery
25	RISER2	Central riser board connector

SAS Backplane Board Connectors

Figure 6-3, Figure 6-4, and Figure 6-5 show the location of the connectors on the three SAS backplane board options.

Figure 6-3. SAS Backplane Board Components: 3.5-inch x6 Option

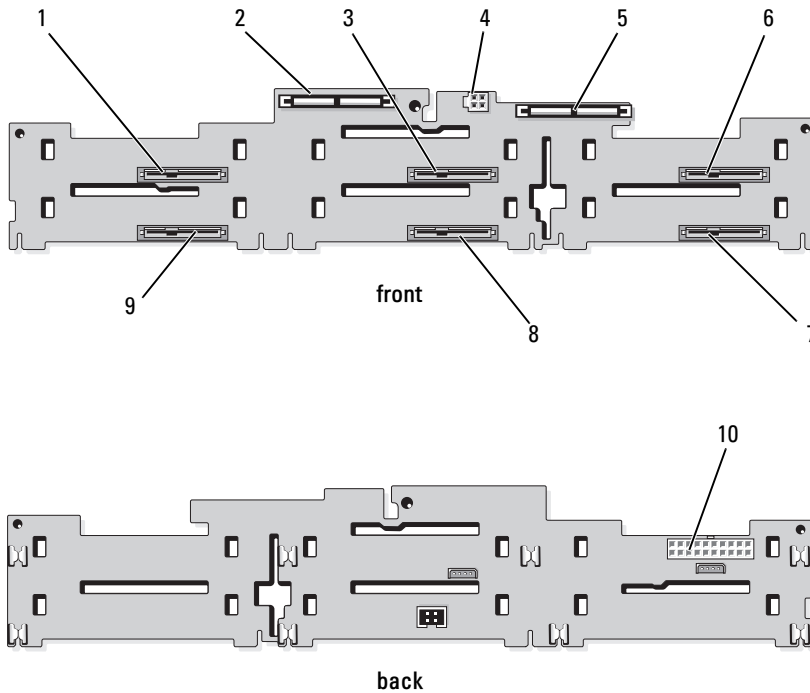

- | | | | | | |
|----|------------------------------|---|-----------------------|---|-------------------|
| 1 | drive 0 (SASDRV0) | 2 | primary SAS (SAS_A) | 3 | drive 2 (SASDRV2) |
| 4 | optical drive power (CD_PWR) | 5 | secondary SAS (SAS_B) | 6 | drive 4 (SASDRV4) |
| 7 | drive 5 (SASDRV5) | 8 | drive 3 (SASDRV3) | 9 | drive 1 (SASDRV1) |
| 10 | backplane power (BP_PWR) | | | | |

Figure 6-4. SAS Backplane Board Components: 3.5-inch x4 Option

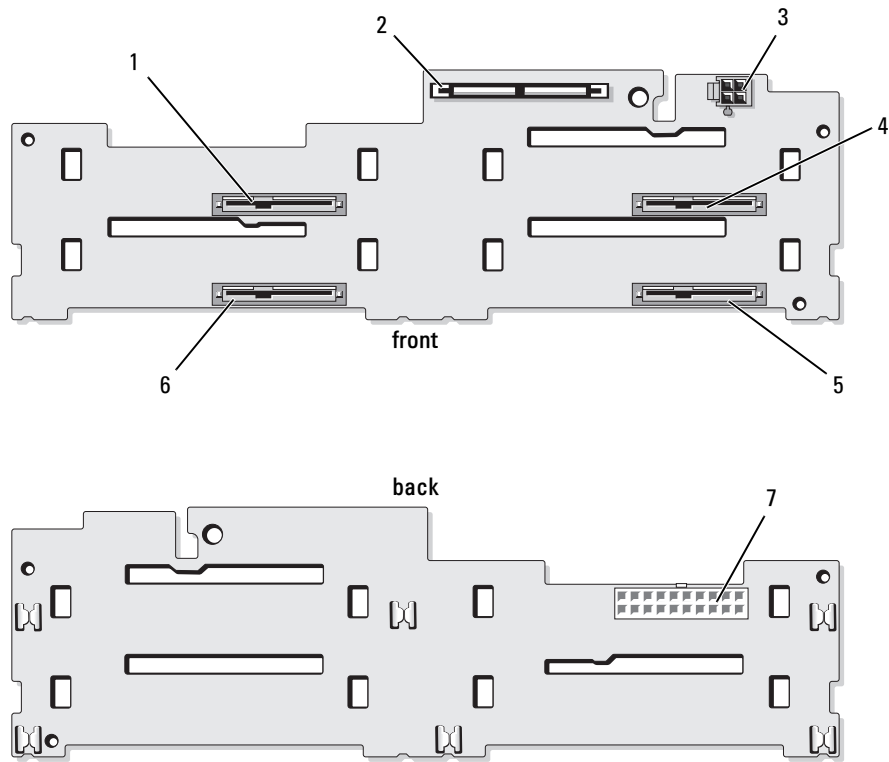

- | | | | | | |
|---|----------------------------|---|-------------------|---|--|
| 1 | drive 0 (SASDRV0) | 2 | SAS (SAS_A) | 3 | tape drive power connector (J_TBU_PWR) |
| 4 | drive 2 (SASDRV2) | 5 | drive 3 (SASDRV3) | 6 | drive 1 (SASDRV1) |
| 7 | backplane power (J_BP_PWR) | | | | |

Figure 6-5. SAS Backplane Board Components: 2.5-inch x8 Option

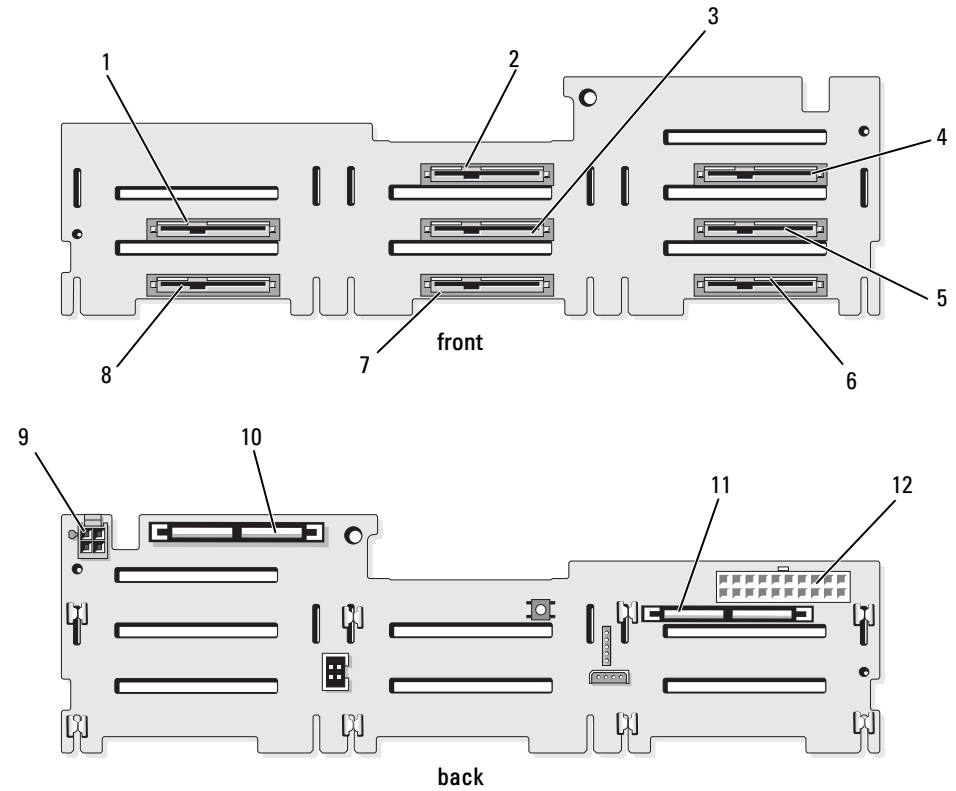

- | | | | | | |
|----|-----------------------|----|---------------------|----|------------------------------|
| 1 | drive 0 (SASDRV0) | 2 | drive 2 (SASDRV2) | 3 | drive 3 (SASDRV3) |
| 4 | drive 5 (SASDRV5) | 5 | drive 6 (SASDRV5) | 6 | drive 7 (SASDRV4) |
| 7 | drive 4 (SASDRV5) | 8 | drive 1 (SASDRV5) | 9 | optical drive power (CD_PWR) |
| 10 | secondary SAS (SAS_B) | 11 | primary SAS (SAS_A) | 12 | backplane power (BP_PWR) |

Sideplane Board Connectors

See Figure 6-6 for the location and description of connectors on the sideplane board.

Figure 6-6. Sideplane Board Connectors

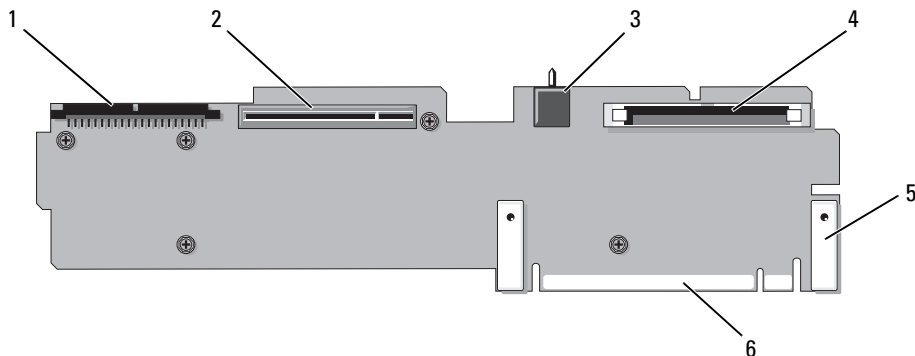

- | | | | | | |
|---|----------------------|---|---|---|--------------------------|
| 1 | control panel (CTRL) | 2 | SAS controller daughter card (PCIE_STORAGE) | 3 | chassis intrusion switch |
| 4 | CD IDE (IDE) | 5 | pin guides (2) | 6 | system board connector |

Expansion-Card Riser-Board Components and PCI Buses

Figure 6-7, Figure 6-8, and Figure 6-9 show the components on the optional PCI-X/PCIe expansion-card riser boards, including the expansion-card slots and buses.

Figure 6-7. Optional PCIe Left Expansion-Card Riser Board Components

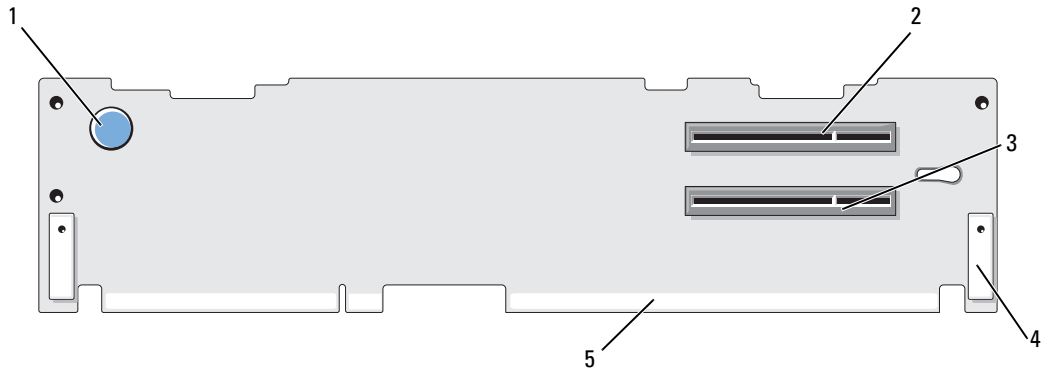

- | | | |
|---------------------|-----------------------------|-----------------------------|
| 1 riser release pin | 2 slot 2 PCIe x8 lane width | 3 slot 3 PCIe x4 lane width |
| 4 pin guide (2) | 5 system board connector | |

Figure 6-8. Optional PCI-X Left Expansion-Card Riser Board Components

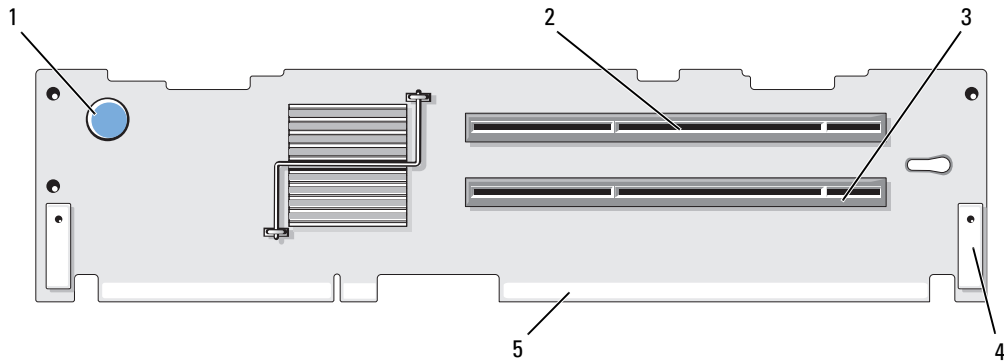

- | | | |
|---------------------|--------------------------|------------------------|
| 1 riser release pin | 2 slot 2 PCI-X 133-MHz | 3 slot 3 PCI-X 133-MHz |
| 4 pin guide (2) | 5 system board connector | |

Figure 6-9. Optional PCIe Expansion-Card Central Riser Board Components

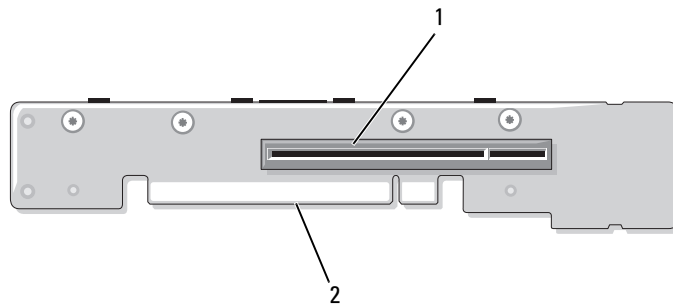

- 1 slot 1 PCI-X - x8 lane width 2 system board connector

Disabling a Forgotten Password

The system's software security features include a system password and a setup password, which are discussed in detail in "Using the System Setup Program" on page 37. The password jumper enables these password features or disables them and clears any password(s) currently in use.

➔ NOTICE: See "Protecting Against Electrostatic Discharge" in the safety instructions in your *Product Information Guide*.

- 1 Turn off the system, including any attached peripherals, and disconnect the system from the electrical outlet.
- 2 Open the system. See "Opening and Closing the System" on page 54.
- 3 Lift up the memory module shroud.
- 4 Remove the jumper plug from the password jumper.
See Figure 6-1 to locate the password jumper (labeled "PWRD_EN") on the system board.
- 5 Close the system.
- 6 Reconnect your system and peripherals to their electrical outlets, and turn on the system.

The existing passwords are not disabled (erased) until the system boots with the password jumper plug removed. However, before you assign a new system and/or setup password, you must install the jumper plug.

✍ NOTE: If you assign a new system and/or setup password with the jumper plug still removed, the system disables the new password(s) the next time it boots.

- 7 Turn off the system, including any attached peripherals, and disconnect the system from the electrical outlet.

- 8** Open the system. See "Opening and Closing the System" on page 54.
- 9** Install the jumper plug on the password jumper.
- 10** Lower the memory module shroud.
- 11** Close the system.
- 12** Reconnect your system and peripherals to their electrical outlets, and turn on the system.
- 13** Assign a new system and/or setup password.
To assign a new password using the System Setup program, see "Assigning a System Password" on page 45.

Getting Help

Technical Assistance

If you need assistance with a technical problem, perform the following steps:

- 1 Complete the procedures in "Troubleshooting Your System" on page 111.
- 2 Run the system diagnostics and record any information provided.
- 3 Make a copy of the Diagnostics Checklist, and fill it out.
- 4 Use Dell's extensive suite of online services available at Dell Support at support.dell.com for help with installation and troubleshooting procedures.

For more information, see "Online Services" on page 147.

- 5 If the preceding steps have not resolved the problem, call Dell for technical assistance.

 **NOTE:** Call technical support from a phone near or at the system so that technical support can assist you with any necessary procedures.

 **NOTE:** Dell's Express Service Code system may not be available in all countries.

When prompted by Dell's automated telephone system, enter your Express Service Code to route the call directly to the proper support personnel. If you do not have an Express Service Code, open the **Dell Accessories** folder, double-click the **Express Service Code** icon, and follow the directions.

For instructions on using the technical support service, see "Technical Support Service" on page 148 and "Before You Call" on page 150.

 **NOTE:** Some of the following services are not always available in all locations outside the continental U.S. Call your local Dell representative for information on availability.

Online Services

You can access Dell Support at support.dell.com. Select your region on the **WELCOME TO DELL SUPPORT** page, and fill in the requested details to access help tools and information.

You can contact Dell electronically using the following addresses:

- World Wide Web
www.dell.com/
www.dell.com/ap/ (Asian/Pacific countries only)
www.dell.com/jp (Japan only)

www.euro.dell.com (Europe only)

www.dell.com/la (Latin American countries)

www.dell.ca (Canada only)

- Anonymous file transfer protocol (FTP)
[ftp.dell.com/](ftp://ftp.dell.com/)

Log in as `user:anonymous`, and use your e-mail address as your password.

- Electronic Support Service
support@us.dell.com
apsupport@dell.com (Asian/Pacific countries only)
support.jp.dell.com (Japan only)
support.euro.dell.com (Europe only)
- Electronic Quote Service
apmarketing@dell.com (Asian/Pacific countries only)
sales_canada@dell.com (Canada only)

AutoTech Service

Dell's automated technical support service—AutoTech—provides recorded answers to the questions most frequently asked by Dell customers about their portable and desktop computer systems.

When you call AutoTech, use your touch-tone telephone to select the subjects that correspond to your questions.

The AutoTech service is available 24 hours a day, 7 days a week. You can also access this service through the technical support service. See the contact information for your region.

Automated Order-Status Service

To check on the status of any Dell™ products that you have ordered, you can go to support.dell.com, or you can call the automated order-status service. A recording prompts you for the information needed to locate and report on your order. See the contact information for your region.

Technical Support Service

Dell's technical support service is available 24 hours a day, 7 days a week, to answer your questions about Dell hardware. Our technical support staff use computer-based diagnostics to provide fast, accurate answers.

To contact Dell's technical support service, see "Before You Call" on page 150 and then see the contact information for your region.

Dell Enterprise Training and Certification

Dell Enterprise Training and Certification is available; see www.dell.com/training for more information. This service may not be offered in all locations.

Problems With Your Order

If you have a problem with your order, such as missing parts, wrong parts, or incorrect billing, contact Dell for customer assistance. Have your invoice or packing slip available when you call. See the contact information for your region.

Product Information

If you need information about additional products available from Dell, or if you would like to place an order, visit the Dell website at www.dell.com. For the telephone number to call to speak to a sales specialist, see the contact information for your region.

Returning Items for Warranty Repair or Credit

Prepare all items being returned, whether for repair or credit, as follows:

- 1** Call Dell to obtain a Return Material Authorization Number, and write it clearly and prominently on the outside of the box.
For the telephone number to call, see the contact information for your region.
- 2** Include a copy of the invoice and a letter describing the reason for the return.
- 3** Include a copy of any diagnostic information (including the Diagnostics Checklist) indicating the tests you have run and any error messages reported by the system diagnostics.
- 4** Include any accessories that belong with the item(s) being returned (such as power cables, media such as CDs and diskettes, and guides) if the return is for credit.
- 5** Pack the equipment to be returned in the original (or equivalent) packing materials.

You are responsible for paying shipping expenses. You are also responsible for insuring any product returned, and you assume the risk of loss during shipment to Dell. Collect-on-delivery (C.O.D.) packages are not accepted.

Returns that are missing any of the preceding requirements will be refused at our receiving dock and returned to you.

Before You Call



NOTE: Have your Express Service Code ready when you call. The code helps Dell's automated-support telephone system direct your call more efficiently.

Remember to fill out the Diagnostics Checklist. If possible, turn on your system before you call Dell for technical assistance and call from a telephone at or near the computer. You may be asked to type some commands at the keyboard, relay detailed information during operations, or try other troubleshooting steps possible only at the computer system itself. Ensure that the system documentation is available.



CAUTION: Before servicing any components inside your computer, see your *Product Information Guide* for important safety information.

Diagnostics Checklist

Name:

Date:

Address:

Phone number:

Service Tag (bar code on the back of the computer):

Express Service Code:

Return Material Authorization Number (if provided by Dell support technician):

Operating system and version:

Peripherals:

Expansion cards:

Are you connected to a network? Yes No

Network, version, and network card:

Programs and versions:

See your operating system documentation to determine the contents of the system's start-up files. If possible, print each file. Otherwise, record the contents of each file before calling Dell.

Description of problem and troubleshooting procedures you performed:

Contacting Dell

To contact Dell electronically, you can access the following websites:

- www.dell.com
- support.dell.com (support)

For specific web addresses for your country, find the appropriate country section in the table below.



NOTE: Toll-free numbers are for use within the country for which they are listed.



NOTE: In certain countries, support specific to Dell XPS™ portable computers is available at a separate telephone number listed for participating countries. If you do not see a telephone number listed that is specific for XPS portable computers, you may contact Dell through the support number listed and your call will be routed appropriately.

When you need to contact Dell, use the electronic addresses, telephone numbers, and codes provided in the following table. If you need assistance in determining which codes to use, contact a local or an international operator.

Country (City) International Access Code Country Code City Code	Department Name or Service Area, Website and E-Mail Address	Area Codes, Local Numbers, and Toll-Free Numbers
Anguilla	General Support	toll-free: 800-335-0031
Antigua and Barbuda	General Support	1-800-805-5924
Argentina (Buenos Aires) International Access Code: 00 Country Code: 54 City Code: 11	Website: www.dell.com.ar E-mail: us_latin_services@dell.com E-mail for desktop and portable computers: la-techsupport@dell.com E-mail for servers and EMC® storage products: la_enterprise@dell.com	Customer Care toll-free: 0-800-444-0730 Technical Support toll-free: 0-800-444-0733 Technical Support Services toll-free: 0-800-444-0724 Sales 0-810-444-3355
Aruba	General Support	toll-free: 800-1578
Australia (Sydney) International Access Code: 0011 Country Code: 61 City Code: 2	Website: support.ap.dell.com E-mail: support.ap.dell.com/contactus General Support	13DELL-133355

Country (City) International Access Code Country Code City Code	Department Name or Service Area, Website and E-Mail Address	Area Codes, Local Numbers, and Toll-Free Numbers
Austria (Vienna)	Website: support.euro.dell.com	
International Access Code: 900	E-mail: tech_support_central_europe@dell.com	
Country Code: 43	Home/Small Business Sales	0820 240 530 00
City Code: 1	Home/Small Business Fax	0820 240 530 49
	Home/Small Business Customer Care	0820 240 530 14
	Preferred Accounts/Corporate Customer Care	0820 240 530 16
	Support for XPS portable computers only	0820 240 530 81
	Home/Small Business Support for all other Dell computers	0820 240 530 14
	Preferred Accounts/Corporate Support	0660 8779
	Switchboard	0820 240 530 00
Bahamas	General Support	toll-free: 1-866-278-6818
Barbados	General Support	1-800-534-3066
Belgium (Brussels)	Website: support.euro.dell.com	
International Access Code: 00	Tech Support for XPS portable computers only	02 481 92 96
Country Code: 32	Tech Support for all other Dell computers	02 481 92 88
City Code: 2	Tech Support Fax	02 481 92 95
	Customer Care	02 713 15 65
	Corporate Sales	02 481 91 00
	Fax	02 481 92 99
	Switchboard	02 481 91 00
Bermuda	General Support	1-800-342-0671
Bolivia	General Support	toll-free: 800-10-0238
Brazil	Website: www.dell.com/br	
International Access Code: 00	Customer Support, Tech Support	
Country Code: 55		0800 90 3355
City Code: 51	Technical Support Fax	51 481 5470
	Customer Care Fax	51 481 5480
	Sales	0800 90 3390
British Virgin Islands	General Support	toll-free: 1-866-278-6820

Country (City) International Access Code Country Code City Code	Department Name or Service Area, Website and E-Mail Address	Area Codes, Local Numbers, and Toll-Free Numbers
Brunei	Technical Support (Penang, Malaysia)	604 633 4966
Country Code: 673	Customer Care (Penang, Malaysia)	604 633 4888
	Transaction Sales (Penang, Malaysia)	604 633 4955
Canada (North York, Ontario)	Online Order Status: www.dell.ca/ostatus	
International Access Code: 011	AutoTech (automated Hardware and Warranty Support)	toll-free: 1-800-247-9362
	Customer Service (Home Sales/Small Business)	toll-free: 1-800-847-4096
	Customer Service (med./large business, government)	toll-free: 1-800-326-9463
	Customer Service (printers, projectors, televisions, handhelds, digital jukebox, and wireless)	toll-free: 1-800-847-4096
	Hardware Warranty Support (Home Sales/Small Business)	toll-free: 1-800-906-3355
	Hardware Warranty Support (med./large bus., government)	toll-free: 1-800-387-5757
	Hardware Warranty Support (printers, projectors, televisions, handhelds, digital jukebox, and wireless)	1-877-335-5767
	Sales (Home Sales/Small Business)	toll-free: 1-800-387-5752
	Sales (med./large bus., government)	toll-free: 1-800-387-5755
	Spare Parts Sales & Extended Service Sales	1 866 440 3355
Cayman Islands	General Support	1-800-805-7541
Chile (Santiago)	Sales and Customer Support	toll-free: 1230-020-4823
Country Code: 56		
City Code: 2		

Country (City) International Access Code Country Code City Code	Department Name or Service Area, Website and E-Mail Address	Area Codes, Local Numbers, and Toll-Free Numbers
China (Xiamen) Country Code: 86 City Code: 592	Technical Support website: support.dell.com.cn Technical Support E-mail: cn_support@dell.com Customer Care E-mail: customer_cn@dell.com Technical Support Fax Technical Support (Dell™ Dimension™ and Inspiron) Technical Support (OptiPlex™, Latitude™, and Dell Precision™) Technical Support (servers and storage) Technical Support (projectors, PDAs, switches, routers, and so on) Technical Support (printers) Customer Care Customer Care Fax Home and Small Business Preferred Accounts Division Large Corporate Accounts GCP Large Corporate Accounts Key Accounts Large Corporate Accounts North Large Corporate Accounts North Government and Education Large Corporate Accounts East Large Corporate Accounts East Government and Education Large Corporate Accounts Queue Team Large Corporate Accounts South Large Corporate Accounts West Large Corporate Accounts Spare Parts	592 818 1350 toll-free: 800 858 2968 toll-free: 800 858 0950 toll-free: 800 858 0960 toll-free: 800 858 2920 toll-free: 800 858 2311 toll-free: 800 858 2060 592 818 1308 toll-free: 800 858 2222 toll-free: 800 858 2557 toll-free: 800 858 2055 toll-free: 800 858 2628 toll-free: 800 858 2999 toll-free: 800 858 2955 toll-free: 800 858 2020 toll-free: 800 858 2669 toll-free: 800 858 2572 toll-free: 800 858 2355 toll-free: 800 858 2811 toll-free: 800 858 2621
Colombia	General Support	980-9-15-3978
Costa Rica	General Support	0800-012-0435

Country (City) International Access Code Country Code City Code	Department Name or Service Area, Website and E-Mail Address	Area Codes, Local Numbers, and Toll-Free Numbers
Czech Republic (Prague)	Website: support.euro.dell.com	
International Access Code: 00	E-mail: czech_dell@dell.com	
Country Code: 420	Technical Support	22537 2727
	Customer Care	22537 2707
	Fax	22537 2714
	Technical Fax	22537 2728
	Switchboard	22537 2711
Denmark (Copenhagen)	Website: support.euro.dell.com	
International Access Code: 00	Technical Support for XPS portable computers only	7010 0074
Country Code: 45	Technical Support for all other Dell computers	7023 0182
	Customer Care (Relational)	7023 0184
	Home/Small Business Customer Care	3287 5505
	Switchboard (Relational)	3287 1200
	Switchboard Fax (Relational)	3287 1201
	Switchboard (Home/Small Business)	3287 5000
	Switchboard Fax (Home/Small Business)	3287 5001
Dominica	General Support	toll-free: 1-866-278-6821
Dominican Republic	General Support	1-800-148-0530
Ecuador	General Support	toll-free: 999-119
El Salvador	General Support	01-899-753-0777
Finland (Helsinki)	Website: support.euro.dell.com	
International Access Code: 990	Technical Support	09 253 313 60
Country Code: 358	Customer Care	09 253 313 38
City Code: 9	Fax	09 253 313 99
	Switchboard	09 253 313 00

Country (City) International Access Code Country Code City Code	Department Name or Service Area, Website and E-Mail Address	Area Codes, Local Numbers, and Toll-Free Numbers
France (Paris) (Montpellier)	Website: support.euro.dell.com	
International Access Code: 00	Home and Small Business	
Country Code: 33	Technical Support for XPS portable computers only	0825 387 129
City Codes: (1) (4)	Technical Support for all other Dell computers	0825 387 270
	Customer Care	0825 823 833
	Switchboard	0825 004 700
	Switchboard (calls from outside of France)	04 99 75 40 00
	Sales	0825 004 700
	Fax	0825 004 701
	Fax (calls from outside of France)	04 99 75 40 01
	Corporate	
	Technical Support	0825 004 719
	Customer Care	0825 338 339
	Switchboard	01 55 94 71 00
	Sales	01 55 94 71 00
	Fax	01 55 94 71 01
Germany (Langen)	Website: support.euro.dell.com	
International Access Code: 00	E-mail: tech_support_central_europe@dell.com	
Country Code: 49	Technical Support for XPS portable computers only	06103 766-7222
City Code: 6103	Technical Support for all other Dell computers	06103 766-7200
	Home/Small Business Customer Care	0180-5-224400
	Global Segment Customer Care	06103 766-9570
	Preferred Accounts Customer Care	06103 766-9420
	Large Accounts Customer Care	06103 766-9560
	Public Accounts Customer Care	06103 766-9555
	Switchboard	06103 766-7000

Country (City) International Access Code Country Code City Code	Department Name or Service Area, Website and E-Mail Address	Area Codes, Local Numbers, and Toll-Free Numbers
Greece	Website: support.euro.dell.com	
International Access Code: 00	Technical Support	00800-44 14 95 18
Country Code: 30	Gold Service Technical Support	00800-44 14 00 83
	Switchboard	2108129810
	Gold Service Switchboard	2108129811
	Sales	2108129800
	Fax	2108129812
Grenada	General Support	toll-free: 1-866-540-3355
Guatemala	General Support	1-800-999-0136
Guyana	General Support	toll-free: 1-877-270-4609
Hong Kong	Website: support.ap.dell.com	
International Access Code: 001	Technical Support E-mail: HK_support@Dell.com	
Country Code: 852	Technical Support (Dimension and Inspiron)	2969 3188
	Technical Support (OptiPlex, Latitude, and Dell Precision)	2969 3191
	Technical Support (PowerApp™, PowerEdge™, PowerConnect™, and PowerVault™)	2969 3196
	Customer Care	3416 0910
	Large Corporate Accounts	3416 0907
	Global Customer Programs	3416 0908
	Medium Business Division	3416 0912
	Home and Small Business Division	2969 3105
India	E-mail: india_support_desktop@dell.com india_support_notebook@dell.com india_support_Server@dell.com	
	Technical Support	1600338045 and 1600448046
	Sales (Large Corporate Accounts)	1600 33 8044
	Sales (Home and Small Business)	1600 33 8046

Country (City) International Access Code Country Code City Code	Department Name or Service Area, Website and E-Mail Address	Area Codes, Local Numbers, and Toll-Free Numbers
Ireland (Cherrywood)	Website: support.euro.dell.com	
International Access Code: 00	E-mail: dell_direct_support@dell.com	
Country Code: 353	Technical Support for XPS portable computers only	1850 200 722
City Code: 1	Technical Support for all other Dell computers	1850 543 543
	U.K. Technical Support (dial within U.K. only)	0870 908 0800
	Home User Customer Care	01 204 4014
	Small Business Customer Care	01 204 4014
	U.K. Customer Care (dial within U.K. only)	0870 906 0010
	Corporate Customer Care	1850 200 982
	Corporate Customer Care (dial within U.K. only)	0870 907 4499
	Ireland Sales	01 204 4444
	U.K. Sales (dial within U.K. only)	0870 907 4000
	Fax/Sales Fax	01 204 0103
	Switchboard	01 204 4444
Italy (Milan)	Website: support.euro.dell.com	
International Access Code: 00	Home and Small Business	
Country Code: 39	Technical Support	02 577 826 90
City Code: 02	Customer Care	02 696 821 14
	Fax	02 696 821 13
	Switchboard	02 696 821 12
	Corporate	
	Technical Support	02 577 826 90
	Customer Care	02 577 825 55
	Fax	02 575 035 30
	Switchboard	02 577 821
Jamaica	General Support (dial from within Jamaica only)	1-800-682-3639

Country (City) International Access Code Country Code City Code	Department Name or Service Area, Website and E-Mail Address	Area Codes, Local Numbers, and Toll-Free Numbers
Japan (Kawasaki)	Website: support.jp.dell.com	
International Access Code: 001	Technical Support (servers)	toll-free: 0120-198-498
Country Code: 81	Technical Support outside of Japan (servers)	81-44-556-4162
City Code: 44	Technical Support (Dimension and Inspiron)	toll-free: 0120-198-226
	Technical Support outside of Japan (Dimension and Inspiron)	81-44-520-1435
	Technical Support (Dell Precision, OptiPlex, and Latitude)	toll-free:0120-198-433
	Technical Support outside of Japan (Dell Precision, OptiPlex, and Latitude)	81-44-556-3894
	Technical Support (PDAs, projectors, printers, routers)	toll-free: 0120-981-690
	Technical Support outside of Japan (PDAs, projectors, printers, routers)	81-44-556-3468
	Faxbox Service	044-556-3490
	24-Hour Automated Order Service	044-556-3801
	Customer Care	044-556-4240
	Business Sales Division (up to 400 employees)	044-556-1465
	Preferred Accounts Division Sales (over 400 employees)	044-556-3433
	Large Corporate Accounts Sales (over 3500 employees)	044-556-3430
	Public Sales (government agencies, educational institutions, and medical institutions)	044-556-1469
	Global Segment Japan	044-556-3469
	Individual User	044-556-1760
	Switchboard	044-556-4300
Korea (Seoul)	E-mail: krsupport@dell.com	
International Access Code: 001	Support	toll-free: 080-200-3800
Country Code: 82	Support (Dimension, PDA, Electronics and Accessories)	toll-free: 080-200-3801
City Code: 2	Sales	toll-free: 080-200-3600
	Fax	2194-6202
	Switchboard	2194-6000

Country (City) International Access Code Country Code City Code	Department Name or Service Area, Website and E-Mail Address	Area Codes, Local Numbers, and Toll-Free Numbers
Latin America	Customer Technical Support (Austin, Texas, U.S.A.)	512 728-4093
	Customer Service (Austin, Texas, U.S.A.)	512 728-3619
	Fax (Technical Support and Customer Service) (Austin, Texas, U.S.A.)	512 728-3883
	Sales (Austin, Texas, U.S.A.)	512 728-4397
	SalesFax (Austin, Texas, U.S.A.)	512 728-4600 or 512 728-3772
Luxembourg	Website: support.euro.dell.com	
International Access Code: 00	Support	342 08 08 075
Country Code: 352	Home/Small Business Sales	+32 (0)2 713 15 96
	Corporate Sales	26 25 77 81
	Customer Care	+32 (0)2 481 91 19
	Fax	26 25 77 82
Macao	Technical Support	toll-free: 0800 105
Country Code: 853	Customer Service (Xiamen, China)	34 160 910
	Transaction Sales (Xiamen, China)	29 693 115
Malaysia (Penang)	Website: support.ap.dell.com	
International Access Code: 00	Technical Support (Dell Precision, OptiPlex, and Latitude)	toll-free: 1 800 880 193
Country Code: 60	Technical Support (Dimension, Inspiron, and Electronics and Accessories)	toll-free: 1 800 881 306
City Code: 4	Technical Support (PowerApp, PowerEdge, PowerConnect, and PowerVault)	toll-free: 1800 881 386
	Customer Care	toll-free: 1800 881 306 (option 6)
	Transaction Sales	toll-free: 1 800 888 202
	Corporate Sales	toll-free: 1 800 888 213

Country (City) International Access Code Country Code City Code	Department Name or Service Area, Website and E-Mail Address	Area Codes, Local Numbers, and Toll-Free Numbers
Mexico	Customer Technical Support	001-877-384-8979
International Access Code: 00		or 001-877-269-3383
Country Code: 52	Sales	50-81-8800
		or 01-800-888-3355
	Customer Service	001-877-384-8979
		or 001-877-269-3383
	Main	50-81-8800
		or 01-800-888-3355
Montserrat	General Support	toll-free: 1-866-278-6822
Netherlands Antilles	General Support	001-800-882-1519
Netherlands (Amsterdam)	Website: support.euro.dell.com	
International Access Code: 00	Technical Support for XPS portable computers only	020 674 45 94
Country Code: 31	Technical Support for all other Dell computers	020 674 45 00
City Code: 20	Technical Support Fax	020 674 47 66
	Home/Small Business Customer Care	020 674 42 00
	Relational Customer Care	020 674 4325
	Home/Small Business Sales	020 674 55 00
	Relational Sales	020 674 50 00
	Home/Small Business Sales Fax	020 674 47 75
	Relational Sales Fax	020 674 47 50
	Switchboard	020 674 50 00
	Switchboard Fax	020 674 47 50
New Zealand	Website: support.ap.dell.com	
International Access Code: 00	E-mail: support.ap.dell.com/contactus	
Country Code: 64	General Support	0800 441 567
Nicaragua	General Support	001-800-220-1006

Country (City) International Access Code Country Code City Code	Department Name or Service Area, Website and E-Mail Address	Area Codes, Local Numbers, and Toll-Free Numbers
Norway (Lysaker)	Website: support.euro.dell.com	
International Access Code: 00	Technical Support for XPS portable computers only	815 35 043
Country Code: 47	Technical Support for all other Dell products	671 16882
	Relational Customer Care	671 17575
	Home/Small Business Customer Care	23162298
	Switchboard	671 16800
	Fax Switchboard	671 16865
Panama	General Support	001-800-507-0962
Peru	General Support	0800-50-669
Poland (Warsaw)	Website: support.euro.dell.com	
International Access Code: 011	E-mail: pl_support_tech@dell.com	
Country Code: 48	Customer Service Phone	57 95 700
City Code: 22	Customer Care	57 95 999
	Sales	57 95 999
	Customer Service Fax	57 95 806
	Reception Desk Fax	57 95 998
	Switchboard	57 95 999
Portugal	Website: support.euro.dell.com	
International Access Code: 00	Technical Support	707200149
Country Code: 351	Customer Care	800 300 413
	Sales	800 300 410 or 800 300 411 or 800 300 412 or 21 422 07 10
	Fax	21 424 01 12
Puerto Rico	General Support	1-800-805-7545
St. Kitts and Nevis	General Support	toll-free: 1-877-441-4731
St. Lucia	General Support	1-800-882-1521
St. Vincent and the Grenadines	General Support	toll-free: 1-877-270-4609

Country (City) International Access Code Country Code City Code	Department Name or Service Area, Website and E-Mail Address	Area Codes, Local Numbers, and Toll-Free Numbers
Singapore (Singapore)	Website: support.ap.dell.com	
International Access Code: 005 Country Code: 65	Technical Support (Dimension, Inspiron, and Electronics and Accessories)	toll-free: 1800 394 7430
	Technical Support (OptiPlex, Latitude, and Dell Precision)	toll-free: 1800 394 7488
	Technical Support (PowerApp, PowerEdge, PowerConnect, and PowerVault)	toll-free: 1800 394 7478
	Customer Care	toll-free: 1 800 394 7430 (option 6)
	Transaction Sales	toll-free: 1 800 394 7412
	Corporate Sales	toll-free: 1 800 394 7419
Slovakia (Prague)	Website: support.euro.dell.com	
International Access Code: 00 Country Code: 421	E-mail: czech_dell@dell.com	
	Technical Support	02 5441 5727
	Customer Care	420 22537 2707
	Fax	02 5441 8328
	Tech Fax	02 5441 8328
	Switchboard (Sales)	02 5441 7585
South Africa (Johannesburg)	Website: support.euro.dell.com	
International Access Code: 09/091	E-mail: dell_za_support@dell.com	
Country Code: 27	Gold Queue	011 709 7713
City Code: 11	Technical Support	011 709 7710
	Customer Care	011 709 7707
	Sales	011 709 7700
	Fax	011 706 0495
	Switchboard	011 709 7700
Southeast Asian and Pacific Countries	Technical Support, Customer Service, and Sales (Penang, Malaysia)	604 633 4810

Country (City) International Access Code Country Code City Code	Department Name or Service Area, Website and E-Mail Address	Area Codes, Local Numbers, and Toll-Free Numbers
Spain (Madrid)	Website: support.euro.dell.com	
International Access Code: 00	Home and Small Business	
Country Code: 34	Technical Support	902 100 130
City Code: 91	Customer Care	902 118 540
	Sales	902 118 541
	Switchboard	902 118 541
	Fax	902 118 539
	Corporate	
	Technical Support	902 100 130
	Customer Care	902 115 236
	Switchboard	91 722 92 00
	Fax	91 722 95 83
Sweden (Upplands Vasby)	Website: support.euro.dell.com	
International Access Code: 00	Technical Support for XPS portable computers only	0771 340 340
Country Code: 46	Technical Support for all other Dell products	08 590 05 199
City Code: 8	Relational Customer Care	08 590 05 642
	Home/Small Business Customer Care	08 587 70 527
	Employee Purchase Program (EPP) Support	20 140 14 44
	Technical Support Fax	08 590 05 594
	Sales	08 590 05 185
Switzerland (Geneva)	Website: support.euro.dell.com	
International Access Code: 00	E-mail: Tech_support_central_Europe@dell.com	
Country Code: 41	Technical Support for XPS portable computers only	0848 33 88 57
City Code: 22	Technical Support (Home and Small Business) for all other Dell products	0844 811 411
	Technical Support (Corporate)	0844 822 844
	Customer Care (Home and Small Business)	0848 802 202
	Customer Care (Corporate)	0848 821 721
	Fax	022 799 01 90
	Switchboard	022 799 01 01

Country (City) International Access Code Country Code City Code	Department Name or Service Area, Website and E-Mail Address	Area Codes, Local Numbers, and Toll-Free Numbers
Taiwan	Website: support.ap.dell.com	
International Access Code: 002	E-mail: ap_support@dell.com	
Country Code: 886	Technical Support (OptiPlex, Latitude, Inspiron, Dimension, and Electronics and Accessories)	toll-free: 00801 86 1011
	Technical Support (PowerApp, PowerEdge, PowerConnect, and PowerVault)	toll-free: 00801 60 1256
	Customer Care	toll-free: 00801 60 1250 (option 5)
	Transaction Sales	toll-free: 00801 65 1228
	Corporate Sales	toll-free: 00801 651 227
Thailand	Website: support.ap.dell.com	
International Access Code: 001	Technical Support (OptiPlex, Latitude, and Dell Precision)	toll-free: 1800 0060 07
Country Code: 66	Technical Support (PowerApp, PowerEdge, PowerConnect, and PowerVault)	toll-free: 1800 0600 09
	Customer Care	toll-free: 1800 006 007 (option 7)
	Corporate Sales	toll-free: 1800 006 009
	Transaction Sales	toll-free: 1800 006 006
Trinidad/Tobago	General Support	1-800-805-8035
Turks and Caicos Islands	General Support	toll-free: 1-866-540-3355

Country (City) International Access Code Country Code City Code	Department Name or Service Area, Website and E-Mail Address	Area Codes, Local Numbers, and Toll-Free Numbers
U.K. (Bracknell) International Access Code: 00 Country Code: 44 City Code: 1344	Website: support.euro.dell.com Customer Care website: support.euro.dell.com/uk/en/ECare/Form/Home.asp E-mail: dell_direct_support@dell.com	
	Technical Support (Corporate/Preferred Accounts/PAD [1000+ employees])	0870 908 0500
	Technical Support for XPS portable computers only	0870 366 4180
	Technical Support (direct and general) for all other products	0870 908 0800
	Global Accounts Customer Care	01344 373 186
	Home and Small Business Customer Care	0870 906 0010
	Corporate Customer Care	01344 373 185
	Preferred Accounts (500–5000 employees) Customer Care	0870 906 0010
	Central Government Customer Care	01344 373 193
	Local Government & Education Customer Care	01344 373 199
	Health Customer Care	01344 373 194
	Home and Small Business Sales	0870 907 4000
	Corporate/Public Sector Sales	01344 860 456
	Home and Small Business Fax	0870 907 4006
Uruguay	General Support	toll-free: 000-413-598-2521

Country (City) International Access Code Country Code City Code	Department Name or Service Area, Website and E-Mail Address	Area Codes, Local Numbers, and Toll-Free Numbers
U.S.A. (Austin, Texas)	Automated Order-Status Service	toll-free: 1-800-433-9014
International Access Code: 011 Country Code: 1	AutoTech (portable and desktop computers)	toll-free: 1-800-247-9362
	Hardware and Warranty Support (Dell TV, Printers, and Projectors) for Relationship customers	toll-free 1-877-459-7298
	Consumer (Home and Home Office) Support for all other Dell products	toll-free: 1-800-624-9896
	Customer Service	toll-free: 1-800-624-9897
	Employee Purchase Program (EPP) Customers	toll-free: 1-800-695-8133
	Financial Services website: www.dellfinancialservices.com	
	Financial Services (lease/loans)	toll-free: 1-877-577-3355
	Financial Services (Dell Preferred Accounts [DPA])	toll-free: 1-800-283-2210
	Business	
	Customer Service and Support	toll-free: 1-800-456-3355
	Employee Purchase Program (EPP) Customers	toll-free: 1-800-695-8133
	Printers and Projectors Support	toll-free: 1-877-459-7298
	Public (government, education, and healthcare)	
	Customer Service and Support	toll-free: 1-800-456-3355
	Employee Purchase Program (EPP) Customers	toll-free: 1-800-695-8133
	Dell Sales	toll-free: 1-800-289-3355 or toll-free: 1-800-879-3355
	Dell Outlet Store (Dell refurbished computers)	toll-free: 1-888-798-7561
	Software and Peripherals Sales	toll-free: 1-800-671-3355
	Spare Parts Sales	toll-free: 1-800-357-3355
	Extended Service and Warranty Sales	toll-free: 1-800-247-4618
	Fax	toll-free: 1-800-727-8320
	Dell Services for the Deaf, Hard-of-Hearing, or Speech-Impaired	toll-free: 1-877-DELLTY (1-877-335-5889)
U.S. Virgin Islands	General Support	1-877-673-3355
Venezuela	General Support	8001-3605

Glossary

This section defines or identifies technical terms, abbreviations, and acronyms used in your system documents.

A — Ampere(s).

AC — Alternating current.

ACPI — Advanced Configuration and Power Interface. A standard interface for enabling the operating system to direct configuration and power management.

ambient temperature — The temperature of the area or room where the system is located.

ANSI — American National Standards Institute. The primary organization for developing technology standards in the U.S.

application — Software designed to help you perform a specific task or series of tasks. Applications run from the operating system.

ASCII — American Standard Code for Information Interchange.

asset tag — An individual code assigned to a system, usually by an administrator, for security or tracking purposes.

backup — A copy of a program or data file. As a precaution, back up your system's hard drive on a regular basis. Before making a change to the configuration of your system, back up important start-up files from your operating system.

backup battery — A battery that maintains system configuration, date, and time information in a special section of memory when the system is turned off.

beep code — A diagnostic message in the form of a pattern of beeps from your system's speaker. For example, one beep, followed by a second beep, and then a burst of three beeps is beep code 1-1-3.

BIOS — Basic input/output system. Your system's BIOS contains programs stored on a flash memory chip. The BIOS controls the following:

- Communications between the processor and peripheral devices
- Miscellaneous functions, such as system messages

bit — The smallest unit of information interpreted by your system.

blade — A module that contains a processor, memory, and a hard drive. The modules are mounted into a chassis that includes power supplies and fans.

BMC — Baseboard management controller.

boot routine — A program that clears all memory, initializes devices, and loads the operating system when you start your system. Unless the operating system fails to respond, you can reboot (also called *warm boot*) your system by pressing <Ctrl><Alt>. Otherwise, you must restart the system by pressing the reset button or by turning the system off and then back on.

bootable diskette — A diskette that is used to start your system if the system will not boot from the hard drive.

BTU — British thermal unit.

bus — An information pathway between the components of a system. Your system contains an expansion bus that allows the processor to communicate with controllers for the peripheral devices connected to the system. Your system also contains an address bus and a data bus for communications between the processor and RAM.

C — Celsius.

cache — A fast storage area that keeps a copy of data or instructions for quick data retrieval. When a program makes a request to a disk drive for data that is in the cache, the disk-cache utility can retrieve the data from RAM faster than from the disk drive.

CD — Compact disc. CD drives use optical technology to read data from CDs.

cm — Centimeter(s).

cmos — Complementary metal-oxide semiconductor.

component — As they relate to DMI, components include operating systems, computer systems, expansion cards, and peripherals that are compatible with DMI. Each component is made up of groups and attributes that are defined as relevant to that component.

COMn — The device names for the serial ports on your system.

control panel — The part of the system that contains indicators and controls, such as the power button and power indicator.

controller — A chip that controls the transfer of data between the processor and memory or between the processor and a peripheral.

conventional memory — The first 640 KB of RAM. Conventional memory is found in all systems. Unless they are specially designed, MS-DOS® programs are limited to running in conventional memory.

coprocessor — A chip that relieves the system's processor of specific processing tasks. A math coprocessor, for example, handles numeric processing.

CPU — Central processing unit. See *processor*.

DC — Direct current.

DDR — Double-data rate. A technology in memory modules that potentially doubles the output.

device driver — A program that allows the operating system or some other program to interface correctly with a peripheral. Some device drivers—such as network drivers—must be loaded from the **config.sys** file or as memory-resident programs (usually, from the **autoexec.bat** file). Others must load when you start the program for which they were designed.

DHCP — Dynamic Host Configuration Protocol. A method of automatically assigning an IP address to a client system.

diagnostics — A comprehensive set of tests for your system.

DIMM — Dual in-line memory module. See also *memory module*.

DIN — *Deutsche Industrie Norm*.

directory — Directories help keep related files organized on a disk in a hierarchical, “inverted tree” structure. Each disk has a “root” directory. Additional directories that branch off the root directory are called *subdirectories*. Subdirectories may contain additional directories branching off them.

DMA — Direct memory access. A DMA channel allows certain types of data transfer between RAM and a device to bypass the processor.

DMI — Desktop Management Interface. DMI enables the management of your system's software and hardware by collecting information about the system's components, such as the operating system, memory, peripherals, expansion cards, and asset tag.

DNS — Domain Name System. A method of translating Internet domain names, such as **www.dell.com**, into IP addresses, such as 143.166.83.200.

DRAM — Dynamic random-access memory. A system's RAM is usually made up entirely of DRAM chips.

DVD — Digital versatile disc.

ECC — Error checking and correction.

EEPROM — Electronically erasable programmable read-only memory.

EMC — Electromagnetic compatibility.

EMI — Electromagnetic interference.

ERA — Embedded remote access. ERA allows you to perform remote, or “out-of-band,” server management on your network server using a remote access controller.

ESD — Electrostatic discharge.

ESM — Embedded server management.

expansion bus — Your system contains an expansion bus that allows the processor to communicate with controllers for peripherals, such as NICs.

expansion card — An add-in card, such as a NIC or SCSI adapter, that plugs into an expansion-card connector on the system board. An expansion card adds some specialized function to the system by providing an interface between the expansion bus and a peripheral.

expansion-card connector — A connector on the system board or riser board for plugging in an expansion card.

F — Fahrenheit.

FAT — File allocation table. The file system structure used by MS-DOS to organize and keep track of file storage. The Microsoft® Windows® operating systems can optionally use a FAT file system structure.

flash memory — A type of EEPROM chip that can be reprogrammed from a utility on diskette while still installed in a system; most EEPROM chips can only be rewritten with special programming equipment.

format — To prepare a hard drive or diskette for storing files. An unconditional format deletes all data stored on the disk.

FSB — Front-side bus. The FSB is the data path and physical interface between the processor and the main memory (RAM).

ft — Feet.

FTP — File transfer protocol.

g — Gram(s).

G — Gravities.

Gb — Gigabit(s); 1024 megabits or 1,073,741,824 bits.

GB — Gigabyte(s); 1024 megabytes or 1,073,741,824 bytes. However, when referring to hard-drive capacity, the term is usually rounded to 1,000,000,000 bytes.

graphics mode — A video mode that can be defined as x horizontal by y vertical pixels by z colors.

group — As it relates to DMI, a group is a data structure that defines common information, or attributes, about a manageable component.

guarding — A type of data redundancy in which a set of physical drives stores data and an additional drive stores parity data. See also *mirroring*, *striping*, and *RAID*.

h — Hexadecimal. A base-16 numbering system, often used in programming to identify addresses in the system's RAM and I/O memory addresses for devices. In text, hexadecimal numbers are often followed by *h*.

headless system — A system or device that functions without having a keyboard, mouse, or monitor attached. Normally, headless systems are managed over a network using an Internet browser.

host adapter — A host adapter implements communication between the system's bus and the controller for a peripheral device. (Hard-drive controller subsystems include integrated host adapter circuitry.) To add a SCSI expansion bus to your system, you must install or connect the appropriate host adapter.

Hz — Hertz.

I/O — Input/output. A keyboard is an input device, and a monitor is an output device. In general, I/O activity can be differentiated from computational activity.

ID — Identification.

IDE — Integrated drive electronics. A standard interface between the system board and storage devices.

integrated mirroring — Provides simultaneous physical mirroring of two drives. Integrated mirroring functionality is provided by the system's hardware. See also *mirroring*.

internal processor cache — An instruction and data cache built into the processor.

IP — Internet Protocol.

IPX — Internet package exchange.

IRQ — Interrupt request. A signal that data is about to be sent to or received by a peripheral device travels by an IRQ line to the processor. Each peripheral connection must be assigned an IRQ number. Two devices can share the same IRQ assignment, but you cannot operate both devices simultaneously.

jumper — Small blocks on a circuit board with two or more pins emerging from them. Plastic plugs containing a wire fit down over the pins. The wire connects the pins and creates a circuit, providing a simple and reversible method of changing the circuitry in a board.

K — Kilo-; 1000.

Kb — Kilobit(s); 1024 bits.

KB — Kilobyte(s); 1024 bytes.

Kbps — Kilobit(s) per second.

KBps — Kilobyte(s) per second.

key combination — A command requiring you to press multiple keys at the same time (for example, <Ctrl><Alt>).

kg — Kilogram(s); 1000 grams.

kHz — Kilohertz.

KMM — Keyboard/monitor/mouse.

KVM — Keyboard/video/mouse. KVM refers to a switch that allows selection of the system from which the video is displayed and for which the keyboard and mouse are used.

LAN — Local area network. A LAN is usually confined to the same building or a few nearby buildings, with all equipment linked by wiring dedicated specifically to the LAN.

lb — Pound(s).

LCD — Liquid crystal display.

LED — Light-emitting diode. An electronic device that lights up when a current is passed through it.

LGA—Land grid array. A type of processor socket. Unlike the PGA, the LGA interface has no pins on the chip; instead, the chip has pads that contact pins on the system board.

Linux — A UNIX-like operating system that runs on a variety of hardware systems. Linux is open source software, which is freely available; however, the full distribution of Linux along with technical support and training are available for a fee from vendors such as Red Hat Software.

local bus — On a system with local-bus expansion capability, certain peripheral devices (such as the video adapter circuitry) can be designed to run much faster than they would with a traditional expansion bus. See also *bus*.

LVD — Low voltage differential.

m — Meter(s).

mA — Milliampere(s).

MAC address — Media Access Control address. Your system's unique hardware number on a network.

mAh — Milliampere-hour(s).

Mb — Megabit(s); 1,048,576 bits.

MB — Megabyte(s); 1,048,576 bytes. However, when referring to hard-drive capacity, the term is often rounded to mean 1,000,000 bytes.

Mbps — Megabits per second.

MBps — Megabytes per second.

MBR — Master boot record.

memory address — A specific location, usually expressed as a hexadecimal number, in the system's RAM.

memory module — A small circuit board containing DRAM chips that connects to the system board.

memory — An area in your system that stores basic system data. A system can contain several different forms of memory, such as integrated memory (ROM and RAM) and add-in memory modules (DIMMs).

MHz — Megahertz.

mirroring — A type of data redundancy in which a set of physical drives stores data and one or more sets of additional drives stores duplicate copies of the data. Mirroring functionality is provided by software. See also *guarding*, *integrated mirroring*, *striping*, and *RAID*.

mm — Millimeter(s).

ms — Millisecond(s).

MS-DOS® — Microsoft Disk Operating System.

NAS — Network Attached Storage. NAS is one of the concepts used for implementing shared storage on a network. NAS systems have their own operating systems, integrated hardware, and software that are optimized to serve specific storage needs.

NIC — Network interface controller. A device that is installed or integrated in a system to allow connection to a network.

NMI — Nonmaskable interrupt. A device sends an NMI to signal the processor about hardware errors.

ns — Nanosecond(s).

NTFS — The NT File System option in the Windows 2000 operating system.

NVRAM — Nonvolatile random-access memory. Memory that does not lose its contents when you turn off your system. NVRAM is used for maintaining the date, time, and system configuration information.

parity — Redundant information that is associated with a block of data.

partition — You can divide a hard drive into multiple physical sections called *partitions* with the **fdisk** command. Each partition can contain multiple logical drives. You must format each logical drive with the **format** command.

PCI — Peripheral Component Interconnect. A standard for local-bus implementation.

PDU — Power distribution unit. A power source with multiple power outlets that provides electrical power to servers and storage systems in a rack.

peripheral — An internal or external device, such as a diskette drive or keyboard, connected to a system.

PGA — Pin grid array. A type of processor socket that allows you to remove the processor chip.

pixel — A single point on a video display. Pixels are arranged in rows and columns to create an image. A video resolution, such as 640 x 480, is expressed as the number of pixels across by the number of pixels up and down.

POST — Power-on self-test. Before the operating system loads when you turn on your system, the POST tests various system components such as RAM and hard drives.

processor — The primary computational chip inside the system that controls the interpretation and execution of arithmetic and logic functions. Software written for one processor must usually be revised to run on another processor. *CPU* is a synonym for processor.

protected mode — An operating mode that allows operating systems to implement:

- A memory address space of 16 MB to 4 GB
- Multitasking
- Virtual memory, a method for increasing addressable memory by using the hard drive

The Windows 2000 and UNIX 32-bit operating systems run in protected mode. MS-DOS cannot run in protected mode.

PS/2 — Personal System/2.

PXE — Preboot eXecution Environment. A way of booting a system via a LAN (without a hard drive or bootable diskette).

RAC — Remote access controller.

RAID — Redundant array of independent disks. A method of providing data redundancy. Some common implementations of RAID include RAID 0, RAID 1, RAID 5, RAID 10, and RAID 50. See also *guarding*, *mirroring*, and *striping*.

RAM — Random-access memory. The system's primary temporary storage area for program instructions and data. Any information stored in RAM is lost when you turn off your system.

RAS — Remote Access Service. This service allows users running the Windows operating system to remotely access a network from their system using a modem.

readme file — A text file, usually shipped with software or hardware, that contains information supplementing or updating the product's documentation.

read-only file — A read-only file is one that you are prohibited from editing or deleting.

ROM — Read-only memory. Your system contains some programs essential to its operation in ROM code. A ROM chip retains its contents even after you turn off your system. Examples of code in ROM include the program that initiates your system's boot routine and the POST.

ROMB — RAID on motherboard.

rpm — Revolutions per minute.

RTC — Real-time clock.

SAS — Serial-attached SCSI.

SATA — Serial Advanced Technology Attachment. A standard interface between the system board and storage devices.

SCSI — Small computer system interface. An I/O bus interface with faster data transmission rates than standard ports.

SDRAM — Synchronous dynamic random-access memory.

sec — Second(s).

serial port — An I/O port used most often to connect a modem to your system. You can usually identify a serial port on your system by its 9-pin connector.

service tag — A bar code label on the system used to identify it when you call Dell for technical support.

simple disk volume — The volume of free space on a single dynamic, physical disk.

SMART — Self-Monitoring Analysis and Reporting Technology. Allows hard drives to report errors and failures to the system BIOS and then display an error message on the screen.

SMP — Symmetric multiprocessing. Used to describe a system that has two or more processors connected via a high-bandwidth link and managed by an operating system, where each processor has equal access to I/O devices.

SNMP — Simple Network Management Protocol. A standard interface that allows a network manager to remotely monitor and manage workstations.

spanning — Spanning, or concatenating, disk volumes combines unallocated space from multiple disks into one logical volume, allowing more efficient use of all the space and all drive letters on a multiple-disk system.

striping — Disk striping writes data across three or more disks in an array, but only uses a portion of the space on each disk. The amount of space used by a "stripe" is the same on each disk used. A virtual disk may use several stripes on the same set of disks in an array. See also *guarding*, *mirroring*, and *RAID*.

SVGA — Super video graphics array. VGA and SVGA are video standards for video adapters with greater resolution and color display capabilities than previous standards.

system board — As the main circuit board, the system board usually contains most of your system's integral components, such as the processor, RAM, controllers for peripherals, and various ROM chips.

system configuration information — Data stored in memory that tells a system what hardware is installed and how the system should be configured for operation.

system diskette — See *bootable diskette*.

system memory — See *RAM*.

System Setup program — A BIOS-based program that allows you to configure your system's hardware and customize the system's operation by setting features such as password protection. Because the System Setup program is stored in NVRAM, any settings remain in effect until you change them again.

system.ini file — A start-up file for the Windows operating system. When you start Windows, it consults the **system.ini** file to determine a variety of options for the Windows operating environment. Among other things, the **system.ini** file records which video, mouse, and keyboard drivers are installed for Windows.

TCP/IP — Transmission Control Protocol/Internet Protocol.

termination — Some devices (such as the last device at each end of a SCSI cable) must be terminated to prevent reflections and spurious signals in the cable. When such devices are connected in a series, you may need to enable or disable the termination on these devices by changing jumper or switch settings on the devices or by changing settings in the configuration software for the devices.

UNIX — Universal Internet Exchange. UNIX, the precursor to Linux, is an operating system written in the C programming language.

uplink port — A port on a network hub or switch used to connect to other hubs or switches without requiring a crossover cable.

UPS — Uninterruptible power supply. A battery-powered unit that automatically supplies power to your system in the event of an electrical failure.

USB — Universal Serial Bus. A USB connector provides a single connection point for multiple USB-compliant devices, such as mice and keyboards. USB devices can be connected and disconnected while the system is running.

utility — A program used to manage system resources—memory, disk drives, or printers, for example.

UTP — Unshielded twisted pair. A type of wiring used to connect systems in a business or home to a telephone line.

V — Volt(s).

VAC — Volt(s) alternating current.

VDC — Volt(s) direct current.

VGA — Video graphics array. VGA and SVGA are video standards for video adapters with greater resolution and color display capabilities than previous standards.

video adapter — The logical circuitry that provides (in combination with the monitor) your system's video capabilities. A video adapter may be integrated into the system board or may be an expansion card that plugs into an expansion slot.

video driver — A program that allows graphics-mode application programs and operating systems to display at a chosen resolution with the desired number of colors. Video drivers may need to match the video adapter installed in the system.

video memory — Most VGA and SVGA video adapters include memory chips in addition to your system's RAM. The amount of video memory installed primarily influences the number of colors that a program can display (with the appropriate video drivers and monitor capabilities).

video resolution — Video resolution (800 x 600, for example) is expressed as the number of pixels across by the number of pixels up and down. To display a program at a specific graphics resolution, you must install the appropriate video drivers and your monitor must support the resolution.

W — Watt(s).

WH — Watt-hour(s).

win.ini file — A start-up file for the Windows operating system. When you start Windows, it consults the **win.ini** file to determine a variety of options for the Windows operating environment. The **win.ini** file also usually includes sections that contain optional settings for Windows application programs that are installed on the hard drive.

Windows 2000 — An integrated and complete Microsoft Windows operating system that does not require MS-DOS and that provides advanced operating system performance, improved ease of use, enhanced workgroup functionality, and simplified file management and browsing.

Windows Powered — A Windows operating system designed for use on NAS systems. For NAS systems, the Windows Powered operating system is dedicated to file service for network clients.

Windows Server 2003 — A set of Microsoft software technologies that enable software integration through the use of XML Web services. XML Web services are small reusable applications written in XML that allow data to be communicated between otherwise unconnected sources.

XML — Extensible Markup Language. XML is a way to create common information formats and to share both the format and the data on the World Wide Web, intranets, and elsewhere.

ZIF — Zero insertion force.

Index

A

alert messages, 35

B

back-panel

features, 17

baseboard management

controller, 48

BMC, 48

batteries

removing and replacing, 96

troubleshooting, 118

battery

RAID, 74

bezel

removing, 53-54

replacing, 54

blank

hard drive, 56

power supply, 64

BMC, 48

boot device

configuring, 76

C

CD drive

troubleshooting, 123

central riser board

installing, 100

removing, 100

checking equipment, 112

configuring

memory, 89

connecting external

devices, 17

connectors

expansion-card riser

board, 142

SAS backplane board, 139

system board, 137

control panel assembly

installing, 106

removing, 105

cooling fan

troubleshooting, 119

cooling fans

removing, 65

replacing, 66

cover

removing, 54

D

damaged systems

troubleshooting, 117

daughter card

SAS, 69-70, 74

Dell

contacting, 151-152

diagnostics

advanced testing options, 132

testing options, 132

when to use, 131

diskette drive

installing, 84

removing, 83

troubleshooting, 121

diskette drive from drive

carrier

removing, 85

diskette drive into drive

carrier

installing, 85

drive blank

installing, 57

removing, 56

drive carrier

SAS hard drive (SATAu), 59

SATA hard drive (SATA), 60

SATA hard drive (SATAu), 61

E

error messages, 37

expansion cards

installation guidelines, 76

installing, 76

removing, 78

troubleshooting, 127

- expansion slots
 - PCI buses, 142
- expansion-card cage
 - removing, 78
 - replacing, 79
- expansion-card riser board
 - connectors, 142
 - PCI buses, 142
- external devices
 - connecting, 17

F

- fan bracket
 - removing, 68
 - replacing, 69
- features
 - back-panel, 17
 - front-panel, 13

G

- guidelines
 - expansion card installation, 76
- guidelines for memory
 - installation, 89

H

- hard drive
 - installing, 57
 - installing SAS in a SATAu drive carrier, 59
 - installing SATA in a SATA drive carrier, 60

- hard drive (*continued*)
 - installing SATA in a SATAu drive carrier, 61
 - removing, 57
 - removing from a drive carrier, 58
 - troubleshooting, 124

- hard drives
 - boot device, 76
 - indicator codes, 15

- hot-plug
 - hard drives, 57

I

- indicators
 - back-panel, 17
 - front-panel, 13
 - hard-drive, 15
 - NIC, 19
 - power, 18
- installing
 - control panel assembly, 106
 - diskette drive, 84
 - diskette drive into drive carrier, 85
 - expansion card, 76
 - expansion card guidelines, 76
 - hard drive blank, 57
 - hard drives, 57
 - left riser board, 98
 - memory, 90
 - memory guidelines, 89
 - optical drive, 82
 - power supply blank, 65
 - processor, 93, 95
 - RAID battery, 74

- installing (*continued*)
 - SAS backplane board, 104
 - SAS controller daughter card, 70
 - SAS hard drive in a SATAu drive carrier, 59
 - SATA hard drive in a SATA drive carrier, 60
 - SATA hard drive in a SATAu drive carrier, 61
 - sideplane board, 102
 - system board, 108
 - tape drive, 86

- integrated NIC TOE
 - activating, 93

- IRQs
 - avoiding conflicts, 112
 - line assignments, 112

J

- jumpers
 - system board, 135

K

- keyboard
 - troubleshooting, 113

L

- left riser board
 - installing, 99
 - removing, 98

M

- memory
 - installation guidelines, 89
 - installing, 90
 - system, 89
 - troubleshooting, 120
- memory modules
 - removing, 92
- messages
 - alert, 35
 - error messages, 37
 - hard-drive indicator codes, 15
 - status LCD, 19
 - system, 28
 - warning, 35
- microprocessors
 - troubleshooting, 128
- mouse
 - troubleshooting, 114

N

- NICs
 - indicators, 19
 - troubleshooting, 116

O

- optical drive
 - installing, 82
 - removing, 81
- options
 - system setup, 38

P

- password
 - disabling, 144
- password features
 - setup, 45
 - system, 45
- passwords
 - setup, 47
 - system, 45
- PCI buses
 - expansion-card riser board, 142
- POST
 - accessing system features, 12
- power
 - indicator, 18
- power supplies
 - removing, 63
 - replacing, 64
 - troubleshooting, 118
- power supply blank, 64
- processor
 - removing, 93, 95
 - upgrades, 93

R

- RAID battery, 74
 - installing, 74
 - removing, 75
- RAID controller (integrated)
 - troubleshooting, 126

- removing
 - battery, 96
 - bezel, 53
 - central riser, 100
 - control panel assembly, 105
 - cooling fan, 65
 - cover, 54
 - diskette drive, 83
 - diskette drive from drive carrier, 85
 - expansion card, 78
 - expansion-card cage, 78
 - fan bracket, 68
 - hard drive blank, 56
 - hard drive from a drive carrier, 58
 - hard drives, 57
 - left riser, 99
 - left riser board, 98
 - memory, 92
 - optical drive, 81
 - power supply, 63
 - power supply blank, 64
 - processor, 93, 95
 - RAID battery, 75
 - SAS backplane board, 103
 - SAS controller daughter card, 69, 74
 - sideplane board, 101
 - system board, 107
 - tape drive, 86
 - tape drive cable retention bracket, 88
- removing and replacing
 - bezel, 54

- replacing
 - battery, 96
 - bezel, 54
 - cooling fan, 66
 - expansion-card cage, 79
 - fan bracket, 69
 - power supply, 64
 - system board, 107
 - tape drive cable retention bracket, 88

S

- safety, 111
- SAS and SAS RAID controller
 - daughter card cabling guidelines, 72
- SAS backplane board
 - connectors, 139
 - installing, 104
 - removing, 103
- SAS controller daughter card
 - installing, 70
 - removing, 69, 74
- SCSI tape drives
 - see *tape drives*
- securing your system, 46
- serial I/O device
 - troubleshooting, 115
- setup password
 - assigning, 47
 - changing, 48
 - using, 47
- setup password enabled
 - working with, 47

- setup password features, 45
- sideplane board
 - installing, 102
 - removing, 101
- startup
 - accessing system features, 12
- support
 - contacting Dell, 151-152
- system
 - opening, 54
- system board
 - connectors, 137
 - installing, 108
 - jumpers, 135
 - removing, 107
 - replacing, 107
- system cooling
 - troubleshooting, 119
- system features
 - accessing, 12
- system messages, 28
- system password
 - assigning, 45
 - changing, 47
 - deleting, 47
 - using, 45
- system password features, 45
- system setup
 - entering, 37, 49
 - options, 38
 - using, 38
- system setup screens
 - console redirection, 43
 - integrated devices, 42

- system setup screens
 - (*continued*)
 - main, 38
 - system security, 43

T

- tape drive
 - installing, 86
 - removing, 86
 - troubleshooting, 123
- tape drive cable retention bracket
 - removing and replacing, 88
- TOE
 - activating integrated NIC TOE, 93
- troubleshooting
 - basic I/O, 114
 - battery, 118
 - CD drive, 123
 - cooling fan, 119
 - damaged system, 117
 - diskette drive, 121
 - expansion cards, 127
 - external connections, 112
 - hard drive, 124
 - keyboard, 113
 - memory, 120
 - microprocessors, 128
 - mouse, 114
 - NIC, 116
 - power supplies, 118
 - RAID controller
 - (integrated), 126
 - serial I/O device, 115
 - start-up routine, 111

troubleshooting (*continued*)
 system cooling, 119
 tape drive, 123
 USB device, 115
 video, 113
 wet system, 116

U

upgrades
 processor, 93
USB device
 troubleshooting, 115
using system setup, 38

V

video
 troubleshooting, 113

W

warning messages, 35
warranty, 11
wet system
 troubleshooting, 116

